



Wheels at work





INDEX



06 GENERAL COMPANY INFORMATION

- 06 COMPANY PROFILE
- 08 YOUR BENEFITS
- 10 GLOBAL FOOTPRINT
- 12 PRODUCT RANGE

14 PART NUMBERS

- 14 COMMERCIAL WHEELS
- 24 INDUSTRIAL WHEELS
- 30 AGRICULTURAL & MULTI - PURPOSE WHEELS
 - V-TRAC
 - CROWN-TRAC

50 TECHNICAL DETAILS

- 50 MAIN DEFINITION
- 58 RIM PROFILES
- 54 WHEEL SPECIFICATIONS
- 56 HOLE TYPE
- 59 WHEEL CENTERING
- 60 OFFSET
- 62 LOAD CAPACITY
- 66 SURFACE TREATMENT
- 68 OFF-ROAD SOLUTIONS
- 70 RINGS FOR MULTI-PIECE WHEELS
- 74 PRODUCT STAMPING
- 76 ECO-WHEELS
- 78 SAFETY & MOUNTING RECOMMENDATIONS
- 80 WARRANTY POLICY

COMPANY PROFILE

JANTSA is one of the largest European manufacturers of wheels for commercial, agricultural, industrial and military applications.

The company stands for:

- The broadest range in the industry
- 40+ years expertise in wheel manufacturing
- OEM supplier quality
- Global presence in more than 85 countries and 6 continents.

With annual production capacity of **2 million wheels per year** and over **1,000 Employees** we are ranked as one of the fastest growing wheel manufacturers.

The mission of JANTSA has always been to satisfy the expectations and requirements of our customers from all over the world in terms of quality, variety, service, and price.

MAIN FACTS

NAME	JANTSA JANT SANAYI ve TICARET A.S.
PROPERTY TYPE	Joint Stock Company (Listed at BIST)
WEB	www.jantsa.com
LOCATION	Umurlu Mah. Organize Sanayi Bölgesi Cad. No: 58-59/1, 09630 Efeler/Aydın/Turkey
YEAR OF ESTABLISHMENT	1977
HEADCOUNT	1029 Employees
MANUFACTURING AREA	100.000 m ² in Umurlu/AYDIN
MANUFACTURING FACILITIES	<ul style="list-style-type: none">• JANTSA 1 Main plant & headquarters - Aydın/Turkey• JANTSA 2 Production of lock and side rings - Aydın/Turkey
PRODUCTION CAPACITY	2 million wheels annually
EXPORT MARKETS	More than 85 countries
SHARE OF EXPORT	75% of the revenue
TECHNICAL COOPERATION	LBF (Fraunhofer institute), Dokuz Eylül University, BV (Bureau Veritas), TUV, TUBITAK and DLG
PRODUCT VARIETY	<ul style="list-style-type: none">• 300 wheel sizes• 7000 wheel models
PRODUCT RANGE	<ul style="list-style-type: none">• Commercial Wheels (Trucks, Buses, Trailers)• Agricultural and Multi-Purpose Wheels (Tractors, Implements, Trailers, Forestry, Harvesters, Sprayers&Row-Crop)• Industrial Wheels (Construction, Material Handling, Earthmoving, Mining)• Military Wheels• Sprayers & Row-Crop



YOUR BENEFITS



QUALITY

We deliver products offering the utmost performance and reliability in the wheel manufacturing industry. Our technological leadership is assured by combining 40+ years of wheel expertise with the cutting-edge engineering know-how.

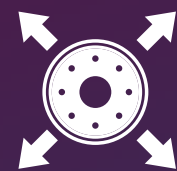

RANGE

With 300 wheel sizes JANTSA has the broadest product range in wheel manufacturing industry worldwide. Balanced on-road and off-road customer portfolio assures our financial sustainability and access to the latest technologies in both segments.



FLEXIBILITY

Speed and time-to-market are the cornerstones of JANTSA's global success. Our everyday work is defined by accelerated new product development and delivery flexibility.



GLOBAL PRESENCE

We are present in 85 countries and 6 continents. JANTSA constantly enlarges its global footprint, while reinforcing local service.



COMPLETE SOLUTIONS

We assure superior customer value through logistic & after-sales service, complete wheel-tire solutions, and in-house tooling.



JANTSA OPERATIONAL EXCELLENCE

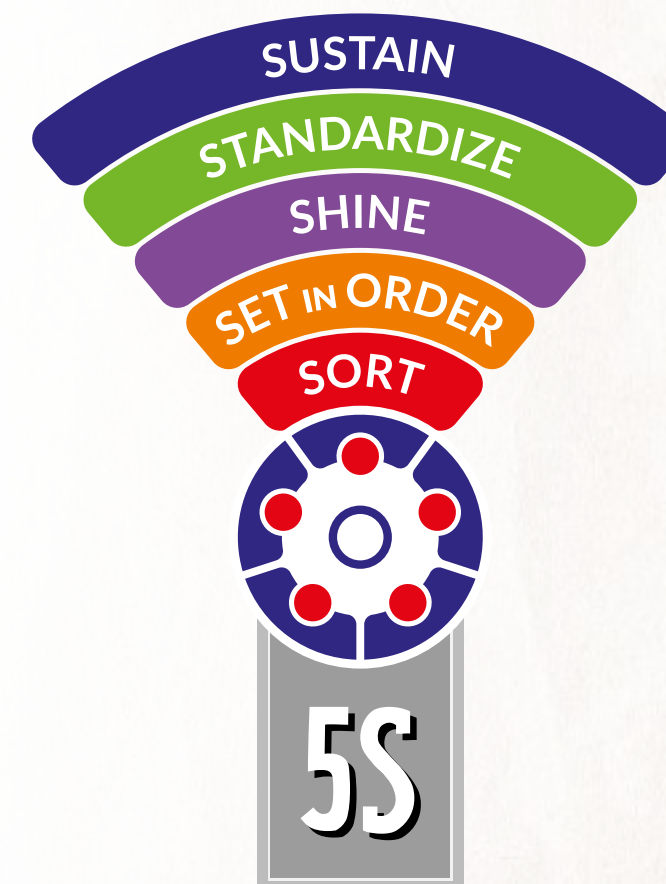

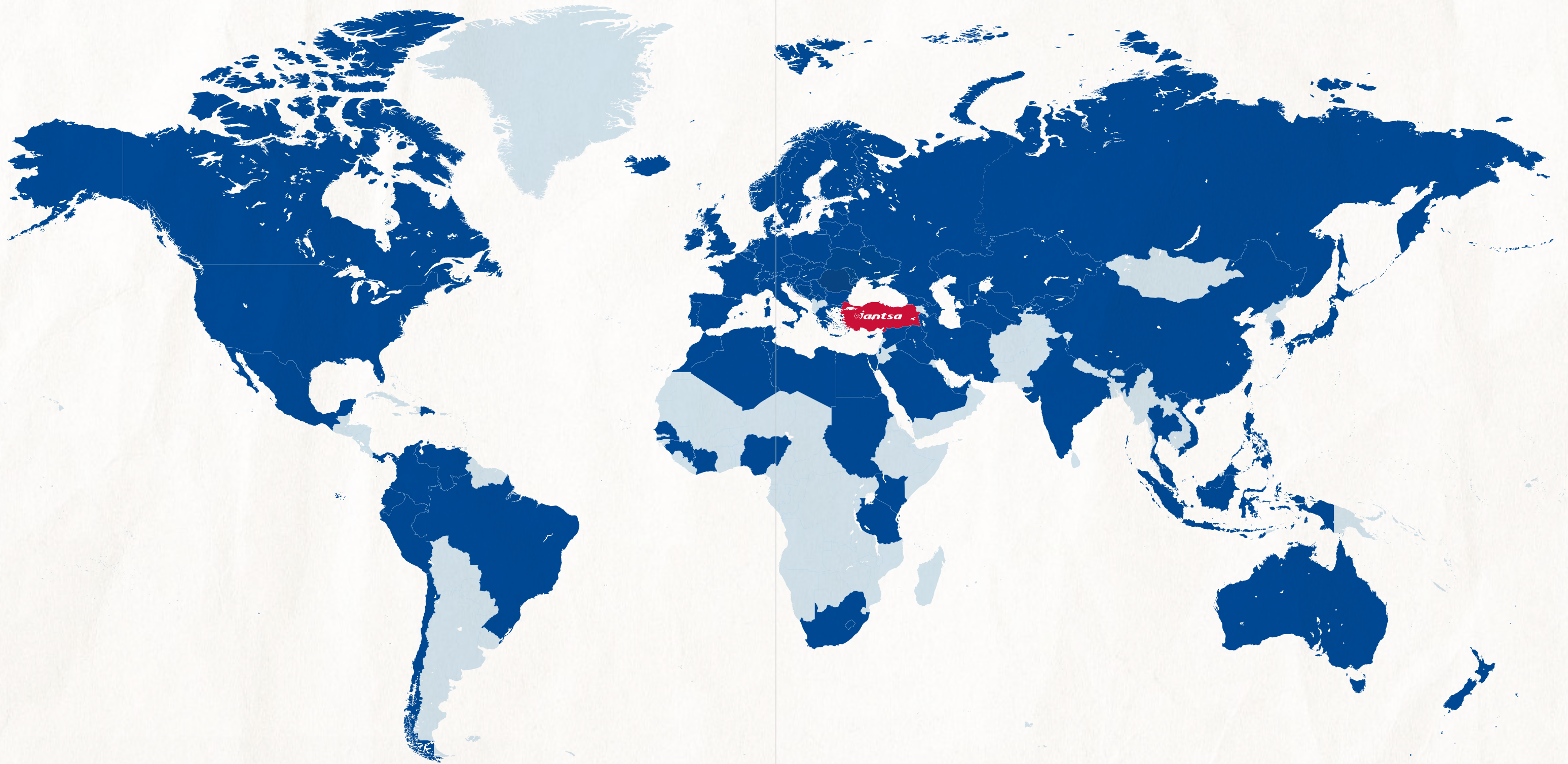

85
EXPORT
COUNTRIES

40+
YEARS
EXPERTISE

2 MILLION
WHEELS/YEAR

7.000
WHEEL
MODELS

PRODUCT RANGE

12	14	14,5	15	15.3	15.5	16	16.1	16.5	17	17.5	18	19	19.5	20	20.25	20.5	21	22	22.5	23	24	24.5	25	26	26.5	28	30	30.5	32	34	36	38	42	44	46	48	50	52	54
----	----	------	----	------	------	----	------	------	----	------	----	----	------	----	-------	------	----	----	------	----	----	------	----	----	------	----	----	------	----	----	----	----	----	----	----	----	----	----	----

COMMERCIAL WHEELS

14	15	16	17.5	19.5	20	22.5	24	24.5
5.50J 6.00J	6.00J 6.0 (3 PCS) 6.5 6.5 (3 PCS) 7.0 7.0 (3 PCS) 7.5 (3 PCS) 6.5 7.0	4.50 5.50 (2 PCS) 5.50 (3 PCS) 5.50 (4 PCS) 5.50J 6.00 (2 PCS) 6.00 (3 PCS) 6.00J 6.50 (2 PCS) 6.50 (3 PCS) 6.50 (4 PCS)	5.25 6.00 6.75 8.25	6.00 6.75 7.50 8.25 11.75 13.00 14.00	6.0 (3 PCS) 6.5 (3 PCS) 7.0 (2 PCS) 7.0 (3 PCS) 7.5 (2 PCS) 7.5 (3 PCS) 8.0 8.0 (2 PCS) 8.0 (3 PCS) 8.5 (2 PCS) 8.5 (3 PCS)	9.0 (3 PCS) 10.00 10.00 (3 PCS) 10.00V (4 PCS) 10.00V (5 PCS) 10.00W (4 PCS) 10.00W (5 PCS) 11.00 (3 PCS) 11.00V (5 PCS) 11 SDC (3 PCS)	6.75 7.50 8.25 9.00 11.75 12.25 13.00 14.00 15.00	8.0 (3 PCS) 8.5 8.5 (2 PCS) 8.5 (3 PCS) 8.5 (4 PCS) 8.5 TL

INDUSTRIAL WHEELS

15	16.5	20	20	21	24	24.5	25	25	26	28	
5.50 5.50 (2 PCS) 6.0 (3 PCS) 6.5 6.5 (3 PCS) 8.0 (3 PCS) 9.75 (3 PCS) 10.5 (3 PCS)	8.25 9.75 12.00	7.5 7.5 (2 PCS) 7.5 (3 PCS) 8.0 8.0 (3 PCS) 8.0V (4 PCS) 8.0V (5 PCS) 8.5 (2 PCS) 8.5 (3 PCS) 8.50V (4 PCS)	8.50V (5 PCS) 10.00V (4 PCS) 10.00V (5 PCS) 10.00W (4 PCS) 10.00W (5 PCS) 11.00 (3 PCS) 11.00V (5 PCS) 20.5 (3 PCS) 26.00 (3 PCS)	18.00 (3 PCS)	8.00TG (3 PCS) 8.5 (3 PCS) 8.5 (4 PCS) 9.00 10.00 10.00 (3 PCS) 10.0 (4 PCS) W13 DW13L	W14L DW14L TW14L W15L DW15L DW16L DW18L	11.75 13.00 15.00	9.5 (3 PCS) 9.5 (5 PCS) 10.00 (3 PCS) 11.25 (3 PCS) 11.25 (5 PCS) 12 12.00 (3 PCS) 13 13.00 (5 PCS) 14	14.00 (3 PCS) 17.00 (3 PCS) 17.00 (5 PCS) 19.50 (5 PCS) 22.00 (5 PCS) 25.00 (3 PCS) 25.00 (5 PCS) 32.00 (3 PCS) 36.00 (3 PCS)	W15L W16L DW16L W18L	W14L W15L W16L DW18L

AGRICULTURAL & MULTI-PURPOSE WHEELS

12	14	14,5	15	15.3	15.5	16	16.1	17	17.5	18	19	19.5	20	20	20.25	20.5	22.5	23	24	24.5	26	26.5	28	30	30.5	32	34	36	38	42	44	46	48	50	52	54	
7.00I 6.00J 7.00	5.50J 6.00J 7.00	10.00 (3 PCS)	3.00D 4.00 5.00F 6.00 6.00 (3 PCS) 6.00J 6.50 (3 PCS) 8 10 13	9.00	13.00	4.00 4.50 5.00 5.50 (3 PCS) 5.50K 6.00 (2 PCS) 6.00 (3 PCS) 6.50 6.50 (2 PCS) 6.50 (3 PCS) 7.00 (3 PCS) W7.50 W8 W10 11LB W12	W10	13.00 16.00	6.75 10.50 14.00	5.50 6.00 9 11 W9 W11 13 13 (3 PCS) 13H2 W13	3.62 4.50	7.50 8.25 11.75 12.25 13.00 14.00	5.50 5.50 (3 PCS) 6.00 (3 PCS) 6.50 (3 PCS) 7.00 (3 PCS) W7 W8 9 14.00 W9 W10	11 (3 PCS) W11 13 13 (3 PCS) W13 14 16 16L	14.00	14.00 16.00 18.00	7.50 8.25 9.00 11.75 13.00 14.00 16.00 18.00 20.00 24.00 28.00	19.00	W7 W8 W9 W10 W12 W13 W14L W15L DW16L DW18L	8.25	DW20B DW25B	20.00 24.00 28.00	W9 W10 W11 W11L W12 W13 W14L W15L W16L	DW12 DW13 DW14 DW14L DW15L DW18L	20.00 24.00 28.00	W8 DW21B DW27B DW30B DW36	W15L DW15L W11 W12 W13 W14L DW14L DW15L DW18L	W8 W9 W11 W12 W14 W15L W16L	DW10 DW11 DW12 DW12L DW14 DW15L DW16 DW16L DW18 DW20 MW23B MW25B	W8 W8 W10 W12 W13 W13 W12	W10 W10 W12 W12 W12 W12	W8 W10 W10 W12 W12 W12	W8 W10 W10 W12 W12 W12	W10 W10 W12 W12 W12	W10 W10 W12 W12	W10 W10 W12 W12	W10 W10 W12 W12

COMING SOON!



Wheels at work

**COMMERCIAL
WHEELS**

COMMERCIAL 5° WHEELS

RIM DIAMETER	WHEEL SIZE	TIRE SIZE	JANTSA PART NUMBER	CENTER HOLE (mm)	P.C.D. (mm)	HOLE TYPE (mm)	NUMBER OF BOLT HOLES	OFFSET (mm)	LOAD CAPACITY @ 100 Km/h
14"	5.50Jx14H2	185/70 R 14	550147	110	160	A15	5	0	850
	6.00Jx14H2	205 R 14C	601402	161	205	A2	6	0	950
15"	6.00Jx15H2	205/65 R15	601505	58	98	A-Ø13,5/ Ø15,5/90°	4	inset 31	1300
	6.0-15	750-15	60801	176	225	B3	10	122	2200
			65155	176	225	Ø26	10	135	2450
	6.5-15	825-15	65157	176	225	B3	10	135	2450
			65160	161	205	A2	6	0	2300
			65161	161	205	B2	6	inset 124	2300
			65164	176	225	B3	10	inset 124	2300
	7.0-15	900-15	70181	176	225	Ø26	10	142	2500
	7.5-15	1000-15	75155	176	225	Ø26	10	155	2600
			75160	176	225	B3	10	160	2600
16"	4.50x16	165/75 R16C	45109	110	140	A15	5	24	640
	5.50-16	750-16	55140	161	205	B17	6	124	1450
			55142	146	203,2	B-Ø29/Ø35/R18	5	124	1450
	5.50Jx16H2	185/75 R16C	550160	130	170	Ø21,5	6	114,5	1200
	6.00-16	750-16	60113	164	222,25	B3	6	132	1650
			60500	161	205	A2	6	0	1450
	6.00Jx16H2	195/75 R16C 215/75 R16C	601601	161	205	B-Ø19/Ø24/R14	6	120	1500
			601602	161	205	B-Ø19/Ø24/R14	6	132	1500
			601610	161	205	B2	6	Inset 115	1500
			601615	161	205	Ø17	6	120	1500
6.50-16	900-16	65120	161	205	B17	6	123	1850	
20"	6.0-20	750-20	60258	221	275	Ø24	8	140	2100
			60261	152,4	203,2	B-Ø31,7/Ø37/ R22,2	5	135	2500
	6.5-20	825-20	65267	165,1	222,25	B-Ø31,7/Ø37/ R22,2	6	153	2600
			65268	161	205	A2	6	0	2600
	7.0-20	9.00-20 270/95 R 20 290/95 R 20	70203	281	335	Ø26	10	153	3000
			70204	281	335	B3	10	153	3000
	7.5-20	10.00 R 20 11.00 R 20 270/95 R 20 300/95 R 20	75202	281	335	Ø26	10	165	3400
			75203	281	335	B3	10	165	3400
			75400	281	335	Ø26	10	165	3400
	8.0-20	11.00 R 20 12.00 R 20 300/95 R 20	80201	281	335	Ø26	10	172	3250
80202			281	335	B3	10	172	3250	
8.5-20	12.00 R 20 300/95 R 20 330/95 R 20 335/80 R 20	85202	281	335	B3	10	180	3750	
		85234	281	335	Ø26	10	130	3750	
		85401	281	335	B3	10	180	3750	
		85602	281	335	Ø26	10	175	4500	
		85610	281	335	Ø26	10	190	4500	
		85654	281	335	8x27 / 2x28	10	185	4500	
9.0-20	1200-20	90203	170,1	225	Ø14,5	10	175	4000	

Not all items are listed in this catalog. Please contact us for any application that you do not see in this catalog.

COMMERCIAL 5° WHEELS

RIM DIAMETER	WHEEL SIZE	TIRE SIZE	JANTSA PART NUMBER	CENTER HOLE (mm)	P.C.D. (mm)	HOLE TYPE (mm)	NUMBER OF BOLT HOLES	OFFSET (mm)	LOAD CAPACITY @ 100 Km/h		
20"	10.00-20	1400 R 20 365/85 R 20 395/85 R 20	100201	281	335	B3	10	151	5000		
			100218	281	335	Ø26	10	0	5000		
			100222	281	335	Ø26	10	214	5000		
			100223	281	335	B3	10	214	5000		
	10.00V-20	1400 R 20 365/85 R 20 395/85 R 20	100266	281	335	B3	10	132	5000		
			100225	281	335	Ø26	10	216	8400		
			100236	281	335	Ø26	10	inset 120	8400		
			100239	281	335	Ø26	10	161	8400		
			100281	281	335	Ø26	10	114	8400		
			100319	281	335	Ø26	10	0	8400		
			100341	221	275	Ø24	8	inset 70	8400		
			100342	281	335	Ø26	10	89	8400		
			100357	221	275	Ø24	8	inset 120	8400		
			100381	281	335	Ø26	10	214	8400		
			10.00W-20	16,00-20	100278	221	275	Ø24	8	inset 120	5600
					100284	281	335	Ø26	10	inset 95	5800
	100298	281			335	Ø26	10	inset 120	5800		
	100325	281			335	Ø26	10	inset 114	5800		
	100329	281			335	Ø26	10	216	5800		
	11.00-20	14,00-20			110210	281	335	Ø26	10	inset 130	4600
11.00V-20	395/85 R 20	110225	221	260	Ø26	8	inset 80	5100			
11-20 SDC	335/80 R 20 MPT	110229	221	275	Ø26	8	inset 120	3550			
		110230	161	205	Ø21,5	6	inset 95	3550			
24"	8.0-24	10.00 R 24 11.00 R 24 12.00 R 24	80244	281	335	Ø26	10	172	4500		
			852400	281	335	Ø26	10	180	5000		
	8.5x24	12.00 R 24	852401	281	335	A3	10	180	5000		
			85277	281	335	Ø26	10	184	4500		
	8.5-24	1200 R 24 325/95 R 24	85282	281	335	Ø26	10	185	4800		
			85800	281	335	B3	10	180	4500		
			85801	281	335	Ø26	10	172	4750		
			85802	281	335	Ø26	10	180	4750		

Not all items are listed in this catalog. Please contact us for any application that you do not see in this catalog.

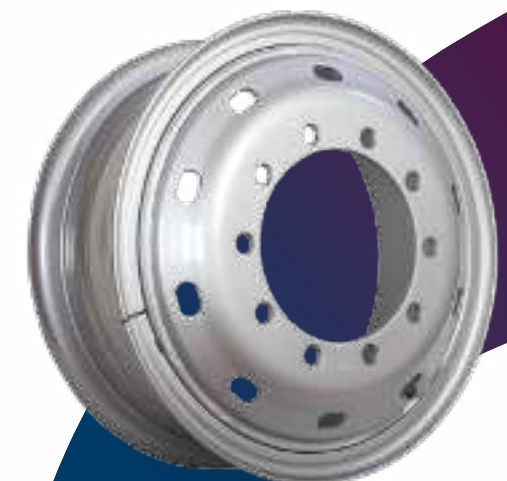

COMMERCIAL 15° DC WHEELS

RIM DIAMETER	WHEEL SIZE	TIRE SIZE	JANTSA PART NUMBER	CENTER HOLE (mm)	P.C.D. (mm)	HOLE TYPE (mm)	NUMBER OF BOLT HOLES	OFFSET (mm)	LOAD CAPACITY @ 100 Km/h		
17.5 "	17.5x5.25	7 R 17.5	525100	161	205	B2	6	124	1600		
		8 R 17.5	525115	150	208	B5	5	115	1600		
		8.5 R 17.5	525123	161	225	Ø20	6	120	1600		
		205/75 R 17.5	525110	176	225	B33	10	116	1850		
	17.5x6.00	8 R 17.5 8.5 R 17.5 9 R 17.5 9.5 R 17.5 205/65 R 17.5 205/75 R 17.5 215/75 R 17.5 225/75 R 17.5	600102	146	203,2	B34	5	127	2400		
			600106	161	205	B2	6	133	2400		
			600126	161	205	A2	6	0	2750		
			600140	176	225	B33	10	133	2750		
			600145	176	225	Ø26	10	133	2750		
			600170	261	300	A33	10	122	2750		
			600174	221	275	Ø24	8	134	2400		
			600180	176	225	B33	10	124	2750		
			600187	164	222,5	B-Ø32,5/Ø37	6	127	1850		
			600725	202	245	B2	6	inset 127	2400		
			600731	161	205	Ø21	6	125	1850		
			600732	161	205	B2	6	127	1850		
			600748	176	225	B3	10	inset 108	2400		
			600764 ALV	164	222,25	B5	6	131	1850		
			17.5x6.75	8 R 17.5 8.5 R 17.5 9.5 R 17.5 10 R 17.5 20.5/65 R 17.5 215/75 R 17.5 225/75 R 17.5 235/75 R 17.5 245/70 R 17.5 265/70 R 17.5	675100	161	205	B2	6	145	2750
					675101	176	225	B3	10	145	3000
	675105	221			275	B2	8	141	2750		
	675110	176			225	Ø26	10	135,5	3000		
	675111	161			205	B2	6	138	2750		
	675116	164			222,25	B5	6	135	3000		
	675128	161			205	A2	6	0	3000		
	675136	176			225	B33	10	145	2750		
	675151	176			225	Ø26	10	145	3000		
	675153	161			205	B2	6	125	2750		
	675156	120,95			165,1	Ø17,4	8	inset -12,7	2750		
	675158	120,95			165,1	Ø17,4	8	inset 4.8	2750		
	675168	176			225	B33	10	145	3000		
	675703	221			275	Ø26	8	142	3000		
	675739	176			225	A33	10	0	3000		
	675757	176			225	Ø26	10	140	3000		
	675772	176			225	B33	10	135	3000		
	675825	221			275	Ø24	8	145	2750		
	675843	176			225	B33	10	inset 127	3100		
	675852 ALV	164			222,25	B5	6	139	2360		
	17.5x8.25	265/55R17,5 265/70R17,5	825175	142,2	203,2	A-Ø31,7Ø37,3/R22,2	5	0	2850		

Not all items are listed in this catalog. Please contact us for any application that you do not see in this catalog.



COMMERCIAL 15° DC WHEELS

RIM DIAMETER	WHEEL SIZE	TIRE SIZE	JANTSA PART NUMBER	CENTER HOLE (mm)	P.C.D. (mm)	HOLE TYPE (mm)	NUMBER OF BOLT HOLES	OFFSET (mm)	LOAD CAPACITY @ 100 Km/h		
19.5 "	19.5x6.00	8.00 R 19.5	600207	140,7	184,15	Ø14,2	6	135	2500		
			600215	149,2	203,2	B5	5	129	2500		
			600216	142,2	200	Ø15,9	8	129	2500		
	19.5x6.75	245/70 R 19,5 265/70 R 19,5	675191	164	222,25	B5	6	145	3100		
			675193	221	275	B33	8	145	3100		
			675510	221	275	Ø24	8	145	2850		
	19.5x7.50	9.5 R 19.5 10 R 19.5 11 R 19.5 245/70 R 19.5 265/70 R 19.5 285/70 R 19.5	750190	176	225	Ø26	10	150	3000		
			750191	176	225	B3	10	156	3000		
			750192	176	225	B33	10	150	3000		
			750316	161	205	A2	6	0	3000		
			750323	221	275	B33	6	148	3000		
			750357	221	275	Ø24	6	156	3000		
			750362	220	285,75	Ø26	6	162,5	3000		
			750377	221	275	A2	6	0	3000		
			750379	221	275	B3	8	156	3000		
			750384	281	335	Ø26	10	137	3250		
			750405	221	275	B2	8	inset 139	3000		
			750409 ALV	221	275	Ø24	8	156	3000		
			19.5x8.25	255/60 R 19.5 285/70 R 19.5 305/70 R 19.5	825102	176	225	Ø26	10	164	3150
					825110	221	275	Ø26	8	164	3150
					825118	221	275	A2	8	0	3350
					825132	176	225	B33	10	160	3150
	825142	221			275	Ø26	8	inset 66	3350		
	825155	176			225	Ø26	10	0	3150		
	825300	161			205	A2	6	0	3350		
	825308	150			203,2	A2	5	0	3150		
	111950	221			275	Ø26	8	0	4250		
	111968	281			335	A-Ø23,8/Ø38,1/R22,2	10		4400		
	19.5x11.75	365/40 R 19.5 385/55 R 19.5 385/65 R 19.5	111987	281	335	Ø26	10	inset 120	4000		
			111992	176	225	B3	10	0	4000		
			112007	221	275	Ø20,5	8	inset -49,5	4300		
			112011	161	205	A2	6	0	4250		
			825300	161	205	A2	6	0	3350		
			825308	150	203,2	A2	5	0	3150		
			131952	281	335	Ø26	10	-50	4300		
	19.5x13.00	425/65 R 19.5	131953	221	275	A3	8	0	4300		
			141960	281	335	B3	10	inset -60	4600		
	19.5x14.00	425/55 R 19.5 445/65 R 19.5	141970	281	335	Ø26	10	120	4500		
			142005	281	335	B33	10	0	4600		
			142010	281	335	Ø26	10	inset 120	4500		

Not all items are listed in this catalog. Please contact us for any application that you do not see in this catalog.



COMMERCIAL 15° WHEELS

RIM DIAMETER	WHEEL SIZE	TIRE SIZE	JANTSA PART NUMBER	CENTER HOLE (mm)	P.C.D. (mm)	HOLE TYPE (mm)	NUMBER OF BOLT HOLES	OFFSET (mm)	LOAD CAPACITY @ 100 Km/h		
22.5"	22.5x6.75	9 R 22.5	675214	281	335	Ø26	10	144	3100		
			675215	165,1	222,25	B5	6	144	3100		
		10 R 22.5 255/70 R 22.5	675216	158,8	222,25	Ø17,4	10	144	3100		
			675220	149,2	203,2	B5	5	146	3100		
	22.5x7.50	10 R 22.5 11 R 22.5 255/70 R 22.5 265/60 R 22.5 275/70 R 22.5	750203	281	335	B3	10	153	3400		
			750204	221	275	B2	8	153	3400		
			750205	281	335	B17	10	153	3400		
			750206	281	335	Ø26	10	153	3400		
			750216	221	275	Ø26	8	153	3400		
			750222	220	285,75	Ø26	10	163,5	3250		
			750237	281	335	Ø26	10	160	3400		
			750240	221	275	B17	8	153	3250		
			750265	221	275	Ø24	8	160	3250		
			750298 ALV	281	335	Ø26	10	160	3750		
			22.5x8.25	10 R 22.5 11 R 22.5 12 R 22.5 255/70 R 22.5 275/80 R 22.5 295/80 R 22.5 315/70 R 22.5	825201	281	335	B3	10	165	3550
					825202	281	335	Ø26	10	165	3550
	825206	281			335	Ø26	10	0	3450		
	825207	221			285	B5	8	165	3550		
	825226	221			275	B3	8	165	3550		
	825252	221,6			285,75	B5	10	168	3000		
	825262	220			285,75	Ø26	10	168	3450		
	825266 ALV	281			335	Ø26	10	165	3750		
	825290	221			285,75	Ø25,4	10	inset 12.25	3450		
	825505	221			275	Ø26	8	inset 65	3950		
	825508	221			275	Ø26	8	168	3450		
	825151	281			335	Ø26	10	165	3550		
	825522	221,5			285,75	A-Ø31,7/Ø37,7/R22,2	10	128	3750		
	22.5x9.00	12 R 22,5 13 R 22.5 315/70 R 22.5 285/60 R 22.5 295/70 R 22.5 315/75 R 22.5 315/80 R 22.5			900249	281	335	Ø26	10	175	3750
			900250	281	335	B3	10	175	3750		
			900251	221,5	285,75	B5	10	178	4200		
			900258	281	335	Ø26	10	175	5000		
			900275	220	285,75	Ø28,5	10	inset 133,5	3750		
			900283	281	335	Ø26	10	118	3750		
			900285 ALV	281	335	B33	10	175	4000		
			900286 ALV	281	335	Ø26	10	175	4000		
			900295	220	285,75	Ø26	10	178	4500		
			900298	221	285,75	B-Ø32,5/Ø37/R22,2	10	79	4000		
			900355 ALV	281	335	B3	10	175	4000		
			900361 ALV	281	335	Ø26	10	175	4000		
	22.5x11.75	15 R 22.5 355/50 R 22.5 365/70 R 22.5	117585	281	335	Ø26	10	inset 45	4600		
			117599	281	335	Ø26	10	inset 135	4600		
			117656	221	275	A3	8	0	5200		
			117671	281	335	A33	10	0	5200		
			117755	281	335	Ø26	10	inset -6	5200		
			117756	281	335	Ø26	10	inset 120	5000		
			117767	281	335	Ø26	10	inset 0	5000		
	22.5x12.25	385/65R22.5	122511	290	335	A-Ø21,5/Ø36,7/R22,2	5	0	5300		
			122512	290	287,75	Ø26	10	inset 130,5	5200		
			122513	220	285,75	Ø26	10	0	5200		
			122514	220	285,75	Ø26	10	inset 101,5	5000		
			122517	221,5	285,75	B5	10	inset 10,5	5000		
			122518	221,5	285,75	B5	10	inset 120,5	5300		

Not all items are listed in this catalog. Please contact us for any application that you do not see in this catalog.

RIM DIAMETER	WHEEL SIZE	TIRE SIZE	JANTSA PART NUMBER	CENTER HOLE (mm)	P.C.D. (mm)	HOLE TYPE (mm)	NUMBER OF BOLT HOLES	OFFSET (mm)	LOAD CAPACITY @ 100 Km/h	
22.5"	22.5x13.00	415/45 R 22.5 425/65R22.5 445/65 R 22.5 445/75 R 22.5	130205	281	335	A3	10	0	5150	
			130207	281	335	Ø26	10	0	5150	
			130216	221	275	A2	8	0	5150	
			130257	220	285,75	Ø26	10	inset 133.5	5400	
			130261	281	335	Ø26	10	inset 120	5150	
			130265	221,5	285,75	B5	10	inset 66.5	5600	
			130273	281	335	B33	10	40	5150	
			130303	281,5	335	A-Ø24/Ø36/R22,2	10	0	5150	
			22.5x14.00	18R22.5 415/45 R 22.5 435/45 R 22.5 445/50 R 22.5 455/45 R 22.5	140203	281	335	B33	10	0
	140206	281			335	Ø26	10	0	5300	
	140248	220			285,75	Ø26	10	-51	5300	
	140253	281			335	B3	10	inset 90	5300	
	140254	281			335	B3	10	inset 120	5300	
	22.5x15.00	445/50 R 22.5 455/45 R 22.5			150201	281	335	Ø26	10	inset 120
			150202	281	335	Ø26	10	0	5400	
			24.5"	24.5x8.25	12 R 24,5	245832	220	285,75	Ø26	10
	245833	220				285,75	Ø26	10	168	3900

Not all items are listed in this catalog. Please contact us for any application that you do not see in this catalog.



COMMERCIAL 15° DEMOUNTABLE WHEELS

RIM SIZE	JANTSA PART NUMBER	RIM OFFSET (mm)	RECOMMENDED VALVE
17.5x6.00	600900	93	TR572
17.5x6.75	675900	100	TR572
22.5x7.50	750900	115	V3. 14.3
22.5x8.25	825900	120	V3. 14.3
22.5x8.25	825901	107	TR573
22.5x8.25	825902	120	TR573
22.5x9.00	900900	120	V3. 14.3
22.5x9.00	900901	127	TR574
24.5x8.25	245900	120	TR573



COMMERCIAL 5° MULTI-PIECE DEMOUNTABLE WHEELS

RIM SIZE	JANTSA PART NUMBER	TIRE SIZE
6.0-15	0250	750-15
6.0-15	0252	825-15
7.0-15	0254	900-15
7.5-15	0256	1000-15
6.5-20	01207	825-20
7.0-20	0257	900-20
7.5-20	0775	1000-20
8.0-20	0468	1100-20
8.5-20	0794	1200-20
8.0-24	0467	1100-24
8.5-24	0516	1200-24





Wheels at work

**INDUSTRIAL
WHEELS**

INDUSTRIAL WHEELS

RIM DIAMETER	WHEEL SIZE	TIRE SIZE	JANTSA PART NUMBER	CENTER HOLE (mm)	P.C.D. (mm)	HOLE TYPE (mm)	NUMBER OF BOLT HOLES	OFFSET (mm)
15"	5.50-15	7.00-15	15550	146	203,2	B-	5	36,5
		7.00 R15						
		205/70 R15						
	6.0-15	7.00-15	60805	97,8	139,7	A-Ø14.4/19/60°	6	8,25
		7.00 R15						
	6.5-15	825-15	65193	221	275	B3	8	inset -40
8.0-15	1100-15	80158	176	176	Ø23,8	10	inset 86	
		80159	161	161	A2	6	0	
9.75-15	12.5-15	97523	221	275	A2	8	0	
10.50-15		10520	223	275	A-Ø25/31/80°	8	inset 30	
16.5"	16.5x8.25	10,00-16.5 31/10.50-16.5	165848	152,4	203,2	A-Ø17/21.5/90°	8	inset 14
			165851	152,4	203,2	B-Ø17/22/90°	8	inset 9,5
			165854	152,4	203,2	A-Ø16,6/20,6/90°	8	20
			165865	222	275	A-Ø25/32/R18	8	inset 24,75
			165868	224	275	A-Ø19/25/90°	8	inset -73,5
			165889	90	150	Ø15	6	inset 5
			165978	152,4	203,2	B-Ø16/20,6/90°	8	0
			165996	71	114,3	A-Ø13,5/19/90°	5	inset 5
	16.5x9.75	320/70-16,5 320/70 R16,5	166000	152,4	203,2	A-Ø17/21,5/90°	8	0
			166009	161	205	A2	6	inset -30
			166014	152,4	203,2	A-Ø17/22/90°	8	inset 37
			166022	221	275	Ø20	8	inset 48,7
			166039	201,6	241,3	A-Ø17,45/23,11/90°	9	inset -25,4
			166059	200,6	241,3	Ø17,5	9	inset 11,4
			166060	117,8	152,4	Ø17,5	6	inset -66
			165127	201,6	241,3	A-Ø17,45/23,11/90°	9	inset -10
			165128	161	205	A2	6	0
			165133	107	139	Ø17,5	5	inset -120,3
	16.5x12.00	33/15.50-16,5	165141	152,4	203,2	A-Ø17/22/90°	8	inset -44,5

Not all items are listed in this catalog. Please contact us for any application that you do not see in this catalog.

INDUSTRIAL WHEELS

RIM DIAMETER	WHEEL SIZE	TIRE SIZE	JANTSA PART NUMBER	CENTER HOLE (mm)	P.C.D. (mm)	HOLE TYPE (mm)	NUMBER OF BOLT HOLES	OFFSET (mm)
20"	7.5-20	10.00R20	75265	281	335	B3	10	0
			75276	230	273	B-Ø17/23/90°	8	inset 38
			75277	281	335	Ø26	10	165
			75401	281	335	B3	10	165
			75408	281	335	B3	10	155
			75419	281,5	335	B3	10	155
	8.0-20	11.00R20	75423	221	275	A33	8	inset -3
			80228	281,2	335	B37	10	177
			80239	221	275	B3	8	0
			80406	281,5	335	B3	10	165
			80600	281	335	Ø26	10	187
			80612	281	335	B3	10	165
	8.0V-20	11,00R20	80631	281	335	Ø26	10	180
			80635	281	335	Ø26	10	177
			80641	241,3	305	Ø20,6	14	inset -124
			85225	281	335	B3	10	172
			85239	176	225	Ø26	10	0
			85419	221	275	B3	8	0
	8.5-20	12.00R20	85607	281	335	Ø26	10	172
			85616	281	335	Ø26	10	177
			85630	281	335	Ø26	10	113
			85639	292,1	335	A-Ø21,5/37,5/R22	5	12,2
			85660	281	335	Ø26	10	0
			85667	281	335	Ø26	10	inset 40
	8.50V-20	12.00R20	85661	371,3	425	Ø26	12	inset 41,5
			85667	281	335	Ø26	10	inset 40
	10.00V-20	385/80R20 395/80R20	100348	221	285,75	Ø20.5	10	-14
			100271	281	335	Ø26	10	100
11.00-20	12.00-20	110020	350,7	410	Ø22	12	-47	
		110231	281	305	Ø17	16	inset 20	
20-20.5/1.5	42/25x20	202050	220	285,75	Ø26	10	inset -60	
		202600	220	285,75	Ø26	10	inset -129	
20-26.00/1.5	48/31x20	210180	281	335	Ø26	10	0	
		210188	281	335	Ø26	10	inset 90	
21"	21-18.00/1.5	24R21	210180	281	335	Ø26	10	0
			210188	281	335	Ø26	10	inset 90

Not all items are listed in this catalog. Please contact us for any application that you do not see in this catalog.



INDUSTRIAL WHEELS

RIM DIAMETER	WHEEL SIZE	TIRE SIZE	JANTSA PART NUMBER	CENTER HOLE (mm)	P.C.D. (mm)	HOLE TYPE (mm)	NUMBER OF BOLT HOLES	OFFSET (mm)				
24"	8.00TG-24	13.00-24	80257	228,6	285,75	Ø23,8	10	inset 90				
	8.5-24	12.00R24	85284	281	335	Ø26	10	185				
			85278	281	335	Ø26	10	172				
			85326	281	335	Ø26	10	0				
			85300	281	335	Ø26	10	180				
			85301	281	335	Ø26	10	193,5				
			85285	281	425	Ø26	12	40				
	9.00x24.00	12.00R24	902418	282,5	335	A-Ø30.1/Ø37.5/R22.2	10	inset -25				
			902443	281,5	335	Ø23,5	10	16				
			902420	282,1	335	Ø23	10	inset -14				
			902409	281,4	335	Ø23,8	10	inset 5,5				
			902427	281,5	335	Ø23,5	10	0				
	10.00-24	14.00-24	102426	281	335	Ø26	10	inset 45				
			102436	382	435	A-Ø32.5/Ø38/R22	12	inset 53				
			102404	371	425	Ø26	24	225				
	10.0-24	14.00R24	102405	371	425	Ø26	24	216				
			102440	371	425	Ø26	24	195				
			102460	281	335	Ø23	10	inset 55				
			102462	371	425	Ø26	12	inset 30				
	W13x24	420/85 R 24 380/75 R 24 420/70 R 24	13265	221	275	B2	8	inset -35				
			13627	221	275	B2	8	inset 100				
			13700	176	225	B3	10	inset 100				
			DW13Lx24	14.9-24 420/70-24	14244	289,5	335	A-Ø23.5/Ø36/R22	5	42,5		
					14257	281	335	Ø24	10	inset -10		
			W14Lx24	420/85 R 24 440/65 R 24	14262	221	275	A3	8	inset 64		
					24152	221,25	275	Ø23	8	0		
			DW14Lx24	440/70-24 17.5L-24	24197	281	335	B3	10	inset -50		
					24162	221	275	Ø24	8	Inset 76,5		
			TW14Lx24	440/80-24	1950-24	16025	281	335	A3	10	87	
					480/80 R 24 500/70 R 24 18,4 R 24 16,9 R 24	18024	221	275	A2	8	0	
			W15Lx24	16,5/85-24 IMP	18025	221	275	A2	8	inset -50		
	245116	201,6			241,3	A-Ø17.5/Ø23,8/90	9	inset 22				
	DW15Lx24	480/80 R 24 500/70 R 24 18,4 R 24 16,9 R 24	245117	201,6	241,3	Ø17,5	9	inset -61,5				
			245118	220,5	275	Ø21,5	8	inset -7,5				
			245127	201,6	241,3	A-Ø17.5/Ø23,8/90	9	inset 59				
			DW16Lx24	19.50-24 480/80 R 24	245131	281	335	A-Ø30.1/Ø36.5/R22.2	10	0		
					245133	285,5	335	A-Ø24/Ø36.3/R22.2	10	inset -37		
			DW18Lx24	540/70 R 24 500/70 R 24 21L-24	245152	281,2	335	A-Ø31.7/Ø37.5/R22.2	11	inset -58		
					245155	221	275	Ø20,5	8	inset -43		
			24.5x11.75	355/55-24.5	245156	281	335	A-Ø31.7/Ø37.5/R22.2	10	inset 32		
					24.5x13.00	15R-24.5	245131	281	335	A-Ø30.1/Ø36.5/R22.2	10	0
							245133	285,5	335	A-Ø24/Ø36.3/R22.2	10	inset -37
24.5x15.00			18R-24.5	245152	281,2	335	A-Ø31.7/Ø37.5/R22.2	11	inset -58			
				245155	221	275	Ø20,5	8	inset -43			
	245156	281		335	A-Ø31.7/Ø37.5/R22.2	10	inset 32					

Not all items are listed in this catalog. Please contact us for any application that you do not see in this catalog.

INDUSTRIAL WHEELS

RIM DIAMETER	WHEEL SIZE	TIRE SIZE	JANTSA PART NUMBER	CENTER HOLE (mm)	P.C.D. (mm)	HOLE TYPE (mm)	NUMBER OF BOLT HOLES	OFFSET (mm)		
25"	9.5-25/1.7"	12.00-25	950025	350,2	400	A3	16	inset -60		
			950028	350,4	400	Ø22	10	inset 190		
	10.00-25/1.5"	14.00-25 385/95R25	100031	281	335	Ø26	10	225		
			100036	221	275	Ø24	8	inset 137		
	11.25-25/1.7"	14.00-25 445/95R25	112535	281	335	B3	10	inset 80		
			112541	281	335	Ø27	10	inset 15		
	11.25-25/2"	16.00-25	112532	371	425	Ø26	12	inset 30		
			112540	368,5	422,25	Ø19,8	12	inset 19		
	12x25	14.00-25	25134	281	335	Ø24	10	inset -10		
	12.00-25/1.3"	15.5-25 395/80R25	120028	281	335	A3	10	inset 15		
			25524	155,5	203,2	Ø19	8	inset -87		
	13x25	18.00R25	130030	371	425	Ø27	12	0		
	14x25	17.5-25	14800	281	335	B3	10	inset 25		
	14.00-25/1.5"	17.5-25 445/80R25	140028	369,5	422,25	A-Ø32.2/Ø40.1/R22.2	12	inset 31.5		
			140034	281	335	A3	10	inset 37		
			140035	281	335	B3	10	inset 37		
			140046	462,3	510	A-Ø21/Ø38/R22.2	19	inset -4		
			140060	282,6	335	A3	10	inset -24		
			170030	371	425	Ø27	12	inset 45		
			170040	281	335	A3	10	inset 70		
			170051	282	335	A-Ø25/Ø30/90	10	inset 50		
			17.00-25/2"	20.5-25	170065	371	425	A3	12	inset 15
			17.00-25/3"	20.5-25	170070	448	500	Ø24	19	inset 10
			19.50-25/2.5"	23.5-25	195254	371	425	Ø26	12	inset 20
			22.00-25/3"	26.5-25	220250	448	500	Ø26	20	Inset 56
	25-25.00/3.5"	29.5-25	250251	371	425	Ø27	24	inset 1.5		
	25-32.00/1.5"	29.5-32	250320	371	425	Ø27	12	inset -42		
	25-36.00/1.5"	66x43.00-25	250360	446	510	Ø24	16	inset 34		
	W15Lx26	420/85 R 26 480/70 R 26	26152	281	335	Ø26	10	0		
			26153	152,4	203,2	Ø19	8	47,5		
			26169	152,4	203,2	Ø18	8	inset 70,25		
			26170	281	335	Ø24	10	inset 15		
W16Lx26	480/70 R 26 540/65 R 26 18.4-26	26174	281	335	A3	10	inset 45			
		14280	289,5	335	A-Ø21.5/Ø38/R22,4	5	41,7			
W14Lx28	480/75 R28 440/65 R28 16,9 R28	14298	281,5	335	A-Ø25.5/Ø38/R22,4	10	inset -57,5			
		14302	281,5	335	Ø22,5	10	inset -1,5			
		28151	281	335	A-Ø24/Ø33/R18,5	10	inset -25			
W15Lx28	480/75R28 16,9R28	28177	281	335	B-Ø23/Ø27/90	10	inset -58			
		28179	281	335	Ø24	10	inset 13			
		16280	151,2	203,2	Ø22	8	inset 50			
W16Lx28	540/65R28	28800	281	335	Ø22	8	inset 50			
DW18Lx28	540/65-28 600/70-28	28800	281	335	A3	10	Inset 45			

Not all items are listed in this catalog. Please contact us for any application that you do not see in this catalog.





Wheels at work

**AGRICULTURAL
and
MULTI-PURPOSE
WHEELS**

AGRICULTURAL and MULTI-PURPOSE WHEELS

RIM DIAMETER	WHEEL SIZE	TIRE SIZE	JANTSA PART NUMBER	CENTER HOLE (mm)	P.C.D. (mm)	HOLE TYPE (mm)	NUMBER OF BOLT HOLES	OFFSET (mm)
12"	7.00Ix12 H2	220/60-12	70128	94	140	A1	5	0
			70129	110	160	A1	5	inset -10
			70132	93	140	Ø16	10	inset 48
			70133	90	120	Ø14	6	inset -8
			70136	94	140	A1	5	0
			70146	161	205	A2	6	0
14"	5.50Jx14	185/70R14 195/70R14	550149	94	140	A1	5	0
	6.00Jx14H2	205 R14 C	601404	161	205	A2	6	inset 5
	7.00x14H2	9,5Lx14	14700	90	150	Ø15	6	inset 20
15"	3.00Dx15	5.00-15	0985	Connected lug 3				
	4.00x15	5.00-15	40150	96	140	A-Ø18.5/Ø24/60°	5	0
	5.00Fx15	7.00-15	15500	92,3	127	A-Ø14.5/18.5/90°	4	0
	6.00x15	7.00-15 7.50-15TR	15600	114.3	152.4	A-Ø15/Ø18.5/90°	6	inset 29
			15601	190.85	241.3	A-Ø17.5/Ø23.8/90°	8	6,5
			15606	122.55	165.1	A-Ø17.5/Ø23.8/90°	8	13
			15615	79.5	114.3	A-Ø14/Ø18/R14	5	0
			601508	60	100	B1	4	inset 30
	6.00Jx15H2	225/70R15	601509	161	205	A2	6	inset 70
			60159	161	205	A2	6	0
	6.00-15	7.50-15 205/70R15	60168	176	225	A2	10	inset -50
			65154	152.4	203.2	B-Ø17.5/Ø23/90°	8	inset -35
	6.50-15	7.50-15 205/70R15	65510	161	205	A2	6	0
			8x15	225/70R15 235/70R15 240/80 R 15 27x10,50-15 27x9,50-15 11L-15 9,5L-15	15804	117.55	152.4	A-Ø15/Ø19/90°
	15825	90			150	Ø15	6	25.5
	15826	161			205	A2	6	inset -57
	15833	101			140	Ø15	6	inset -2.5
	10x15	29x12.5 -15 29x13.5 -15 320/70R15 280/70R15 380/60-15	10152	117.5	152.4	A-Ø15/Ø21/90°	6	inset 22.5
			10155	161	205	Ø19.5	6	inset 10
			10175	161	205	A2	6	inset 35
			10176	94	140	Ø15	5	inset -25
			10177	161	205	A-Ø19/Ø27/90°	6	inset 6
	13x15	31x15.5 - 15 33x15.5 - 15 400/45 R15	13153	93.5	140	Ø15	10	
			13155	117.4	152.4	A-Ø15/Ø20/90°	6	-6.5
13162			161	205	A2	6	0	
13163			161	205	A2	6	inset -37	
13169			94	140	B1	5	0	
13408			93.3	140	Ø15	5	inset -16	
13416			107	139	Ø17.5	5	inset -120	
13426			94	140	A-Ø15/Ø27/R16	5	inset -55	
13430			161	205	A2	6	inset -70	
13431			161	205	A2	6	inset -55	

Not all items are listed in this catalog. Please contact us for any application that you do not see in this catalog.
*Marked part numbers are Adjustable Wheels.



AGRICULTURAL and MULTI-PURPOSE WHEELS

RIM DIAMETER	WHEEL SIZE	TIRE SIZE	JANTSA PART NUMBER	CENTER HOLE (mm)	P.C.D. (mm)	HOLE TYPE (mm)	NUMBER OF BOLT HOLES	OFFSET (mm)						
15.3"	9.00X15.3	10.0/11,5 - 15.3 10.0/75 - 15.3 12.5/80 - 15.3 320/80-15,3 300/80-15,3 260/70-15,3	91535	161	205	A2	6	inset -8						
			91538	161	205	A2	6	0						
			91543	94	140	A1	5	0						
			91592	142	190	A-	8	inset -30						
			91595	90	125	Ø13	5	27.7						
			91603	93.2	140	A-Ø15.3/Ø27/R14	5	inset -30						
			91612	96	140	A1	5	inset -6						
			91615	161	205	A2	6	inset 20						
			91620	161	205	A2	6	0						
			15.5"	13.00x15.5	400/60-15.5 400/55-15.5 400/50-15.5 400/45-15.5	130155	161	205	A2	6	0			
130156	161	205				A2	6	inset -35						
130158	161	205				A2	6	inset -15						
130704	152.4	203.2				A-Ø15.8/Ø23/90°	8	0						
130705	161	205				B2	6	0						
130718	161	205				A2	6	inset -15						
40139	85	130				Ø12.5	4	inset -24						
4.00x16	6.00-16		45111	117.55	152.4	A-Ø14.2/Ø18/90°	6	45						
			45112	161	205	A2	6	0						
			45125	94	140	A1	5	0						
			45127	85	130	Ø15.5	4	44.5						
			45135	135	175	A-Ø20/Ø25/90°	5	inset -25						
4.50x16	6.00-16 6.50-16		45143	95	140	A1	5	inset 46						
			5.00x16	6.00/6.50-16 6.50/7.00-16		50113	94	140	A1	5	0			
						5.50x16	6.50/7.00-16 7.50-16		55104	161	205	A2	6	0
									55105	117.55	152.4	A-Ø14.2/Ø18/90°	6	inset 20
									55130	127	165	A-Ø16.7/Ø21/R12	5	inset -12
55609	117.55	152.4							A-Ø15/Ø19/90°	6	inset 28.6			
55622	85	130	Ø15	4	29,75									
55635	118	152.4	A-Ø17/Ø23/90°	6	inset 27									
55642	110	165	A1	5	0									
5.50Kx16H2	195/75R16C 205/75R16C		550174	146	203.2	B34	5	116.5						
			5.50-16	7.50-16		55121	161	205	A2	6	0			
55124	161	205				B-Ø21.5/Ø26/R16	6	135						
55317	152.4	203.2				B-Ø17.5/Ø22/90°	8	23						
6.00x16	9.00-16		16611	122	162	A-Ø18/Ø25/90°	6	inset -4.5						
			16612	145	190	A-Ø20/Ø27/90°	8	inset -4.5						
			16614	112	152.4	Ø20	6	inset 25						
			16615	163.5	205.5	Ø19	6	28.25						
			16624	152.4	203.2	B-Ø17.4/Ø22.2/90°	8	inset 28.5						
			16625	90	150	Ø15	6	38						
			16629	90.3	150	Ø15	6	inset 33						
			16631	117.5	152.4	A-Ø12/Ø18/90°	6	inset 29						
			60147	146	203.2	A-Ø29/Ø34/R22	5	inset -23.5						
			60605	145	190	A-Ø20/Ø27/90°	8	inset -4.5						
			6.00-16	7.50-16		16650	161	205	A2	6	0			
65105	161	205				A2	6	0						
6.50x16	9.00-16		71600	161	205	A2	6	0						
			16754	161	205	A2	6	0						

Not all items are listed in this catalog. Please contact us for any application that you do not see in this catalog.
*Marked part numbers are Adjustable Wheels.

AGRICULTURAL and MULTI-PURPOSE WHEELS

RIM DIAMETER	WHEEL SIZE	TIRE SIZE	JANTSA PART NUMBER	CENTER HOLE (mm)	P.C.D. (mm)	HOLE TYPE (mm)	NUMBER OF BOLT HOLES	OFFSET (mm)		
16"	W8x16	10.5/65 - 16 230/80 - 16 10,00-16 250/80 - 16 270/75 - 16	16800	161	205	A2	6	0		
			16801	117.55	152.4	A-Ø14.2/Ø18/90°	6	0		
			16805	117.55	152.4	A-Ø14.2/Ø18/90°	6	inset -13.5		
			16825	110	160	A1	5	inset -20		
			16826	117.55	152.4	A-Ø14.2/Ø18/90°	6	inset -25.5		
			16830	165	210	A-Ø20/Ø25/R22	6	inset -3.5		
			16848	152.6	203.2	A-Ø17/Ø22/90°	8	54		
			16849	153.8	203.2	Ø21	8	inset -17.5		
	16887*	80	135	Ø18	8	Inset 87				
	W10x16	11.00-16SL 270/75 - 16 280/70 R 16 300/70 R 16	16018	152.4	203.2	A-Ø16.6/Ø22.6/90°	8	inset -38		
			16019	117.4	152.4	A-Ø15/Ø19/90°	6	Inset 28.5		
			16022	142	185	Ø19	6	inset -30		
	11LBx16 H2	13,0/55-16 13,0/75-16 14,0/65-16 340/55-16	11160	161	205	A2	6	inset -15		
W12x16	13,6 R 16	16120	117.6	152.4	Ø15	6	inset -48			
16.1"	W10x16.1	13,50-16 10SL 16,5L-16,10	16110	132	170	A-Ø20/Ø24.6/60°	6	inset -81		
17"	13.00x17	15.0/55-17 420/55-17 380/55-17	130170	161	205	A2	6	0		
			130173	161	205	A2	6	inset -40		
			130177	221	275	A2	8	0		
			130180	161	205	A2	6	inset -85		
			130185	152.4	203.2	A-Ø16.6/Ø22/90°	8	inset -16		
			130193	152.4	203.2	A-Ø16.6/Ø22.6/90°	8	inset -38		
			130195	161	205	A2	6	inset -40		
			130199	93	140	Ø16	10	inset -65		
			130500	161	205	A2	6	inset -45		
			130504	155	203.2	A-Ø14.5/Ø26.2/R14	8	103.5		
			130527	221	275	A2	8	inset -50		
			16.00x17	19/45-17 480/45-17 520/50-17	160170	161	205	A2	6	0
					160171	161	205	A2	6	inset -35
	160173	221			275	A2	8	0		
	160179	221			275	A2	8	inset -35		
	160180	152.4			203.2	A-Ø17.5/Ø23/90°	8	inset -38		
	160181	161			205	A2	6	inset -50		
	160186	161			205	A2	6	inset -70		
	17.5x6.75	9 R 17.5 9.5 R 17.5 10 R 17.5 215/75 R 17.5 225/75 R 17.5 235/75 R 17.5	675105	221	275	B2	8	141		
			675108	161	205	A2	6	0		
675134			203.2	241.3	Ø16.6	9	inset -32			
675136			176	225	B33	10	145			
675143			161	205	B2	6	145			
675153			161	205	B2	6	125			
675162			121.3	165.1	Ø17.4	8	0			
675173			221	275	B2	8	132			
675174			161	205	B2	6	132			
675704			221	275	A2	8	141			
675708			221	275	A2	8	0			
17.5x10.5			14 R 17.5	105175	273	314.3	A-Ø17,4/Ø21,6/90°	8	15	
				105184	152.4	203.2	A-Ø16,5/Ø22,5/90°	8	inset 6	
				105185	221	275	Ø20.6	8	inset -76	
				105191	202	241.3	A-Ø17,4/Ø23,8/90°	9	inset -25.4	
				105192	221	275	A2	8	0	
				105201	154	203.2	A-Ø17,5/Ø23,8/90°	8	0	
	140175	221		275	A2	8	0			
	140176	161		205	A2	8	0			
17.5x14.00	400/65 L 17,5	140175	221	275	A2	8	0			
		140176	161	205	A2	8	0			

Not all items are listed in this catalog. Please contact us for any application that you do not see in this catalog.
*Marked part numbers are Adjustable Wheels.

AGRICULTURAL and MULTI-PURPOSE WHEELS

RIM DIAMETER	WHEEL SIZE	TIRE SIZE	JANTSA PART NUMBER	CENTER HOLE (mm)	P.C.D. (mm)	HOLE TYPE (mm)	NUMBER OF BOLT HOLES	OFFSET (mm)
18"	5.50x18	7.50-18	55185	85	130	Ø15	4	inset 34
	6.00x18	7.50-18	18600	90	150	Ø15.5	6	65
	9x18	10.5/80-18 12.5/80-18	18931	161	205	A2	6	0
			18932	221	275	A2	8	0
			18981	149	203.2	Ø20.5	5	-160
			18982	115.1	152.4	Ø15	6	inset -60
			18984	221	275	Ø20.6	8	inset 31
			18988	160.8	205	Ø20	6	inset 20
			19004*	221	275	Ø19	8	inset 35
			18900	161	205	A2	6	0
	W9x18	10.5/80-18 12.5/80-18	18914	221	275	A2	8	0
			11189	221	275	A2	8	0
	11x18	340/80R18 340/80 - 18 320/65 R 18	11190	161	205	A2	6	0
			11199	221	275	A3	8	0
			11200	221	275	B3	8	inset 40
			11300	221	275	A2	8	inset 55
	W11x18	340/80R18 340/80 - 18 320/65 R 18	11182	161	205	A2	6	0
			11183	221	275	A2	8	0
	W13x18	15.0/70-18	13181	221	275	A2	8	0
			13184	161	205	A2	6	0
13x18	15.5/70 R18 405/70 R18	13185	221	275	A2	8	0	
		13188	221	275	B3	8	0	
		13189	152.4	203.2	Ø18	8	25	
		13194	161	205	A2	6	0	
13x18H2	15.5/70 R18 405/70 R18	13195	221	275	A3	8	0	
		13500	221	275	A3	8	0	
		13506	221	275	B3	8	inset 40	
		18131	221	275	A2	8	0	
13-18	15.0/70-18	18132	221	275	A3	8	0	
		18134	165	210	A-20/Ø26/R22	6	0	
		18135	145	190	Ø20	8	0	
		18137	161	205	A2	6	0	
		18138	161	205	A2	6	0	
19"	3.62x19	6.00-19	36219	115	152	Ø15	6	30
	4.50x19	7.50-19	45190	117.7	152.4	B-Ø15/Ø18/90°	6	55

Not all items are listed in this catalog. Please contact us for any application that you do not see in this catalog.
*Marked part numbers are Adjustable Wheels.



AGRICULTURAL and MULTI-PURPOSE WHEELS

RIM DIAMETER	WHEEL SIZE	TIRE SIZE	JANTSA PART NUMBER	CENTER HOLE (mm)	P.C.D. (mm)	HOLE TYPE (mm)	NUMBER OF BOLT HOLES	OFFSET (mm)
19.5"	19.5x7.50	10 R 19.5 11 R 19.5 265/70 R 19.5	750194	161	205	A2	6	0
			750195	221	275	A2	8	0
			750301	161	205	A2	6	0
			750350	221	275	Ø24	8	156
	19.5x8.25	285/70 R 19.5	825100	161	205	A2	6	0
			825101	221	275	A2	8	0
	19.5x11.75	15 R 19.5 365/40 R 19.5 385/65 R 19.5	111953	161	205	A2	6	0
			111954	221	275	A2	8	0
			111966	281	335	A3	10	0
			111979	201.6	241.3	A-Ø17.4/Ø23.8/90°	9	inset 39.5
			111994	272.2	314.3	A-Ø16/Ø23.8/90°	8	72.4
			112005	161	205	A2	6	inset -50
			112028	285	335	A-Ø23.5/Ø38/R22.2	10	inset -12
	19.5x12.25	385/55 R19,5	122700	117.6	152.4	Ø15	6	-48.5
	19.5x13.00	425/65 R 19,5 425/55 R 19,5 445/65 R 19,5	131961	221	275	A2	8	0
			131962	161	205	A2	6	0
			131963	281	335	A33	10	0
			131966	221	275	A3	8	0
			131971	285.75	335	A-Ø23.5/Ø38.1/R22.2	10	inset 21
			131984	176	225	B33	10	0
			131992	221	275	A2	8	inset -50
			131994	161	205	A2	6	inset -50
			141956	161	205	A2	6	0
	19.5x14.00	445/65 R 19,5 445/45 R 19,5 435/50 R 19,5 425/55 R 19,5	141957	221	275	A2	8	0
141986			176	225	A3	10	0	
141990			161	205	A2	6	inset -75	
142016			201.6	241.3	A-Ø17.45/Ø23/90°	9	inset -13	
142035			281.5	335	B3	10	inset -75	
20552			170.5	220	A-Ø16/Ø20/90°	6	40	
20555			110	160	B1	5	20	
20"	5.50x20	7.50-20	55202	161	205	A2	6	0
	5.50-20	7.50-20	60204	221	275	A2	8	0
	6.00-20	8.25-20	65202	161	205	A2	6	0
	6.50-20	9.00-20	65214	221	275	A3	8	0
	W7x20	210/95 R 20 250/85 R 20	72200	102	161	Ø14.5	6	inset 52
	7.00-20	9.00-20	70102	161	205	A2	6	0
	W8x20	250/85R20 275/80R20	82000*	221	275	Ø19	8	inset 5
			82008*	153	203.2	Ø17	8	inset -22
	9x20	300/70R20 13/80R20 260/80R20 260/70R20 275/80R20	92026	161	205	A2	6	0
			92032	120.6	165.1	Ø15.9	8	0
			92040	110.1	150	Ø17	6	inset -55

Not all items are listed in this catalog. Please contact us for any application that you do not see in this catalog.
*Marked part numbers are Adjustable Wheels.



AGRICULTURAL and MULTI-PURPOSE WHEELS

RIM DIAMETER	WHEEL SIZE	TIRE SIZE	JANTSA PART NUMBER	CENTER HOLE (mm)	P.C.D. (mm)	HOLE TYPE (mm)	NUMBER OF BOLT HOLES	OFFSET (mm)
20"	W9x20	320/85R20 250/85R20 11.2R20	92027	203.2	241.3	A-Ø16.2/Ø22.2/90°	9	inset 27.5
			92038*	152.4	203.2	Ø17	8	inset 53
			92048	161	205	B-Ø21.5/Ø27/90°	6x6	inset 30
	W10x20	12.R-20 320/85R20 280/85R20	20105*	221	275	Ø19	8	-39
			20108	221	285.75	Ø21.5	10	-14
			20502	117.6	152.4	Ø15	6	inset -23.5
	10-20	14.00-20	10201	161	205	A2	6	0
	11x20	340/80R20 375/75R20 335/80R20 365/80R20 405/70R20 360/80-20	20123	161	205	A2	6	0
			20125	221	275	A2	8	0
			20312	221	275	A3	8	inset 45
			20314	221	275	B3	8	0
			20318	221	275	A2	8	inset -17
			20128	222.4	275	Ø20.6	8	16
	W11x20	320/85R20 380/70R20 420/65R20	20331	201.6	241.3	A-Ø17.5/Ø23/90°	9	0
	11-20	14.00-20	11201	161	205	A2	6	0
	13x20	420/65R20 420/75R20 425/75R20 400/70-20 16/70R20	20143	221	275	A3	8	0
			20150	221	275	A2	8	0
			20155	221	275	A3	8	inset 10
			20160	221.5	275	A-Ø25.5/Ø38/R22	8	inset -10
			20170	221	275	A2	8	inset -25
	W13x20	380/75R20 380/70R20 440/65R20 420/65R20	20134	161	205	A2	6	0
	20197	221	275	A3	8	inset 70		
	20207	221	275	A3	8	inset -40		
	13-20	15,5-20	13219	281	335	A3	10	0
	14x20	420/75R20 420/70R20 460/65-20 16.0/70-20	13222	221	285	A3	8	0
			14213	221	275	A2	8	0
			14215	161	205	A2	6	0
			14216	152.4	203.2	Ø20	8	62.2
			14229	291	335	A-Ø21.5/Ø38/R22.4	5	0
	W14x20	440/65R20 400/65R20	14218	152.4	203.2	Ø16.6	8	inset -50.7
	14228	201.6	241.3	A-Ø17.5/Ø27/90°	9	inset -39.7		
	14233	152.4	203.2	A-Ø19/Ø24/R14	8	inset -10		
16x20	500/55-20	160501	221	275	A2	8	0	
		160502	161	205	A2	6	0	
		160504	221.4	275	B3	8	inset 25.5	
		160513	221	275	A2	8	inset -70	
		160515	231	260	A1	12	0	
160518	221	275	A2	8	inset -50			
16Lx20	500/55-20	160522	221	275	Ø23	8	inset -32	

Not all items are listed in this catalog. Please contact us for any application that you do not see in this catalog.
*Marked part numbers are Adjustable Wheels.



AGRICULTURAL and MULTI-PURPOSE WHEELS

RIM DIAMETER	WHEEL SIZE	TIRE SIZE	JANTSA PART NUMBER	CENTER HOLE (mm)	P.C.D. (mm)	HOLE TYPE (mm)	NUMBER OF BOLT HOLES	OFFSET (mm)
20.25"	20.25x14.00	465/65R20.5	205143	221	275	A2	8	0
	20.5x14.00	465/65R20.5	205145	221	275	A2	8	0
20.5"	20.5x16.00	525/65R20.5	205160	281	335	Ø26	10	inset 70
			205162	281	335	Ø26	10	inset 60
	20.5x18.00	24R20.5	205163	281	335	B3	10	0
			24R20.5	281	335	B33	10	0
22.5"	22.5x7.50	275/80 R 22.5 265/60 R 22.5 10 R 22.5 11 R 22.5	205181	281	335	A3	10	-50
			750201	221	275	A2	8	0
			750202	161	205	A2	6	0
			750243	165.1	222.25	Ø19.8	6	0
			750244	281	335	A3	10	inset -150
			750289	121.1	165.1	Ø17.4	8	0
	22.5x8.25	11 R 22.5 12 R 22.5 275/80R22.5 295/80R22.5	825204	161	205	A2	6	0
			825205	221	275	A2	8	0
			825222	221	275	A3	8	0
			825256	281	335	A3	10	inset -159
			825274	152.4	203.2	B-Ø16.6/Ø20.6/90°	8	inset -35.3
			825298	152.4	203.2	A-Ø16.6/Ø22.6/90°	8	inset -38
			825511	152.4	203.2	B-Ø16.6/Ø20.6/90°	8	inset -35.3
			825525	281	335	A3	10	inset -159
	22.5x9.00	12R22.5 13R22.5 295/80R22.5 315/70 R 22.5 315/80 R 22.5	900220	161	205	A2	6	0
			900222	221	275	A2	8	0
			900223	221	275	A3	8	0
			900234	281	335	A3	10	0
	22.5x11.75	15R22.5 365/70R22.5 385/65R22.5	117555	221	275	A2	8	0
			117561	161	205	A2	6	0
			117579	221	275	A3	8	0
			117611	281	335	A3	10	0
			117612	201.6	241.3	Ø17.5	9	inset -3
			117695	221	275	A2	8	inset -70
			117698	152.4	203.2	A-Ø16.6/Ø22/90°	8	inset -33
			117721	281	335	B33	10	inset 34
	22.5x13.00	16.5R22.5 425/65R22.5 415/45 R 22.5	130247	281	335	B33	10	0
			130256	221	275	A2	8	0
130268			221.2	285.75	Ø20.6	10	0	
130272			152.4	203.2	A-Ø16.6/Ø22/90°	8	0	
130274			152.4	203.2	A-Ø16.6/Ø22.6/90°	8	0	
130286			221	285.75	A-Ø30/Ø37.5/R22.2	10	0	
130302			221	285.75	Ø20.6	10	0	
130309			221	275	Ø24	8	inset 5.5	

Not all items are listed in this catalog. Please contact us for any application that you do not see in this catalog.
*Marked part numbers are Adjustable Wheels.



AGRICULTURAL and MULTI-PURPOSE WHEELS

RIM DIAMETER	WHEEL SIZE	TIRE SIZE	JANTSA PART NUMBER	CENTER HOLE (mm)	P.C.D. (mm)	HOLE TYPE (mm)	NUMBER OF BOLT HOLES	OFFSET (mm)
22.5"	22.5x14.00	18R22.5 465/65R22.5 415/45 R 22.5 445/70 R 22.5	140216	221	275	A2	8	0
			140219	281	335	A3	10	0
			140260	281	335	A3	10	inset 40
			140281	281	335	A3	10	inset -50
	22.5x16.00	550/60-22.5 500/45-22.5	162493	281	335	Ø26	10	inset -25
			22.5xAG 16.00	550/60-22.5 500/45-22.5	162284	281	335	A3
	22.5xAG 16.00 H2	550/60-22.5 500/45-22.5	162291	221	275	A2	8	0
			162295	281	335	A3	10	0
			162306	281	335	A3	10	inset -50
			162307	281	335	A2	10	inset -50
			162319	281	335	A2	10	0
			162323	221	275	B2	8	inset -50
			162373	221	275	A2	8	inset -50
			162397	221	287.75	Ø20.5	10	inset -48
			162398	152.4	203.2	A-Ø16.6/Ø22/90°	8	inset -38
			22.5xAG 18.00 H2	560/55R22.5 560/60R22.5	180225	281	335	A3
	22.5xAG 20.00 H2	600/55-22.5 650/50R-22.5 650/40 R 22.5	200229	281	335	A3	10	0
			200232	281	335	A3	10	inset -50
			200233	221	275	A2	8	0
			200234	221	275	A2	8	inset -50
			200262	221	275	B3	8	10
			200507	281	335	A3	10	inset -60
			200555	221	285.75	Ø20	10	0
			200557	220	285.75	Ø25	10	inset -26
			200606	281.5	335	B3	10	inset -15
			22.5xAG 24.00 H2	700/50-22.5	240225	221	275	A2
	240233	281			335	A3	10	0
	240234	281			335	A3	10	inset -50
240248	281	335			B3	10	inset -70	
240517	220	285.75			Ø25	10	inset -76	
22.5xAG 28.00 H2	850/40 B 26.5	225280	281	335	A3	10	0	
23"	19.00x23	30/21.5R-23	190232	281	335	A3	10	inset -50

Not all items are listed in this catalog. Please contact us for any application that you do not see in this catalog.
*Marked part numbers are Adjustable Wheels.

AGRICULTURAL and MULTI-PURPOSE WHEELS

RIM DIAMETER	WHEEL SIZE	TIRE SIZE	JANTSA PART NUMBER	CENTER HOLE (mm)	P.C.D. (mm)	HOLE TYPE (mm)	NUMBER OF BOLT HOLES	OFFSET (mm)
24"	W7x24	240/85R24 240/85R24 9,5R24	72400	161	205	A2	6	inset -66.5
			72403*	221	275	Ø19	8	inset 80
	W8x24	250/85R24 240/85R24 9,5R24	24804	152.5	203.2	A-Ø16.6/Ø21.7/90°	8	inset -50
			24817*	152.7	203.2	A-Ø16.6/Ø20.8/90°	8	inset 80
	W9x24	320/85R24 280/85R24	24900	221	275	Ø18.5	8	inset 35
	W10x24	14.00-24	24113	161	205	B2	6	0
			24624*	145	190	B-Ø20/Ø25/90°	8	inset 47
			24629	152.4	203.2	Ø17.5	8	67
			24630	221	285	A-Ø32.5/Ø37.5/R22	8	0
	W12x24	80/85 R 24 340/85 R 24 380/75 R 24	24310*	290.5	330	Ø16.5	8	114.7
			24367*	221	275	Ø21	8	0
			24409*	152.4	203.2	Ø16	8	inset -10
			24410*	153	203.2	Ø17	8	inset -35
	W12Lx24	80/85 R 24 340/85 R 24 380/75 R 24	24383*	221	275	Ø21.5	8	-127
			24393	152.52	203.2	A-Ø16.6/Ø20.8/90°	8	inset -50
	W13x24	380/70 R 24	13246	221	275	A2	8	0
			13266*	290.5	330	Ø16.5	8	inset 50
			13269	221	275	A3	8	inset -105
			13271	221	275	Ø24	8	inset 65
			13277	152.4	203.2	Ø15	8	inset -44
	W14Lx24	420/70 R 24	13702*	152.4	203.2	Ø16	8	inset -44
			14254	161	205	Ø17	6	inset 20
			14255	152.4	203.2	Ø19	8	67
	W15Lx24	16,5/85-24 IMP	14261*	40				inset 50
			24173	280	335	Ø23.8	10	26.2
			24174	153	203.2	A1	8	inset -117.2
			24187	152.4	203.2	Ø15	8	inset -168
			24188	135	170	Ø17	6	inset -124
			24189	282	335	A-Ø23.5/Ø32/R18	10	inset -45
	DW16Lx24	500/70 R 24 460/70 R 24 19,5L 24 18,4 R24	24190*	110	152.4	Ø19	8	inset -16.5
24195			152.52	203.2	B-Ø16.6/Ø20.8/90°	8	91	
16027			180	230	A-Ø20/Ø25/R22	6	inset -81	
16028			180	230	A-Ø20/Ø25/R22	6	inset -40	
16043			281	335	A3	10	0	
DW18Lx24	540/70 R 24 500/70 R 24 21L 24	16052	221	275	B3	8	40	
		18026	145	210	B-Ø32/Ø37/R22	8	Inset 140	
		18032	281	335	B3	10	inset -50	
		18041	222.25	285.75	A-Ø28.5/Ø37/R22.3	10	0	

Not all items are listed in this catalog. Please contact us for any application that you do not see in this catalog.
*Marked part numbers are Adjustable Wheels.



AGRICULTURAL and MULTI-PURPOSE WHEELS

RIM DIAMETER	WHEEL SIZE	TIRE SIZE	JANTSA PART NUMBER	CENTER HOLE (mm)	P.C.D. (mm)	HOLE TYPE (mm)	NUMBER OF BOLT HOLES	OFFSET (mm)
24.5"	24.5x8.25	12 R 24,5	245825	152,4	203,2	B-Ø16,6/Ø20,6/90	8	inset -38
26"	DW20Bx26	23,1-26 620/75R26 620/70R26	20260	281	335	A3	10	0
			20262	281	335	A3	10	inset -100
			20263	221	275	A2	8	0
			20282	221	275	Ø24	8	inset -41
			20289	152.4	230.2	Ø20	8	inset -75
			20298	281	335	Ø24	10	94.5
	DW25Bx26	28L-26 30.50L-26	20618	281	335	A3	10	inset -50
			25260	281	335	A3	10	0
			25276	221	275	Ø24	8	inset -88
			25282	220	285.75	Ø20.6	10	0
26.5"	26.5xAG 20.00 H2	600/65 R 26,5 650/60 B 26,5 600/55 - 26,5 680/55 R 26,5	25297	223.3	285.75	Ø20.6	10	inset -130
			25308	281	335	A3	10	inset -100
			200267	221	275	B2	8	inset -50
			200268	281	335	B3	10	inset -50
			200269	281	335	A3	10	0
			200275	281	335	B3	10	inset -100
			200295	281	335	A3	10	inset 20
			200811	281	335	A3	10	inset 40
	26.5xAG 24.00 H2	800/45 R 26,5 750/45 - 26,5 710/45 - 26,5 750/55 R 26,5	200825	302	340	A-Ø20/Ø25.5/R15	20	0
			200835	281	335	A3	10	0
			240266	281	335	A3	10	0
			240267	281	335	B3	10	inset -50
			240277	281	335	B3	10	inset -25
			240278	221	275	A2	8	inset -100
26.5xAG 28.00 H2	800/40 - 26,5 850/40 B 26,5	240283	281	335	B3	10	inset -100	
		240289	281	335	A3	10	inset -50	
		240800	281	335	A3	10	inset -75	
		240815	221	285.75	Ø24	10	0	
		280265	281	335	A3	10	0	
		280270	281	335	A3	10	inset -50	
26.5"			280277	281	335	A3	10	inset -25
			280288	281	335	Ø26	10	0

Not all items are listed in this catalog. Please contact us for any application that you do not see in this catalog.
*Marked part numbers are Adjustable Wheels.



AGRICULTURAL and MULTI-PURPOSE WHEELS

RIM DIAMETER	WHEEL SIZE	TIRE SIZE	JANTSA PART NUMBER	CENTER HOLE (mm)	P.C.D. (mm)	HOLE TYPE (mm)	NUMBER OF BOLT HOLES	OFFSET (mm)
28"	W9x28	250/85 R 28 320/70 R 28 11,2 - 28	28901	161	205	B2	6	0
			28906*	180	230	B-Ø18/Ø23/90°	6	inset 105
	W10x28	360/70 R 28 320/70 R 28 12,4 - 28	28104*	109.5	152.4	B-Ø19/Ø25/90°	8	175
			28109*	109.5	152.4	B-Ø19/Ø25/90°	8	inset -91
	W11x28	12.5-28	28616	161	205	B2	6	inset -30
			28618*	109.5	152.4	B-Ø19/Ø26,9/90°	8	inset 19.3
	W11Lx28	380/85 R28 340/85 R28 320/85 R28	28603*	150.1	203.2	Ø19	8	81
	W12x28	13.6-28	28126*	152.4	203.2	B-Ø19/Ø26,9/90°	8	inset 121.4
			28300	152.4	203.2	Ø17	8	inset 5
	W13x28	14,9-28	13290*	152.4	203.2	Ø20	8	inset 74
			13292*	152.4	203.2	A1	8	inset 50
	W13Lx28	14,9-28	13280*	152.4	203.2	Ø17	8	inset -35
	W14Lx28	16,5/85-28 420/85 R28 480/75 R28	14324	281	335	A-Ø22/Ø29/R18	10	0
			14327	290	335	A-Ø21/Ø36/R21.5	5	inset 32
14332*			152.4	203.2	Ø21	8	inset 50	
W15Lx28	420/85 R28 480/75 R28	28173*	281	335	Ø24	5	inset 56	
W16Lx28	540/75 R28 480/75 R28	16280	151.2	203.2	Ø22	8	inset 50	
30"	DW12x30	420/70 R 30	30120	101.701	165.1	B-Ø32.1/Ø36.9/ R22.2	6	31.5
	W13x30	420/70 R 30	30131*	150.1	203.2	Ø19,8	8	inset 20
			30137*	221	275	Ø24	8	inset -80
	DWW13x30	480/70 R 30	30139	220	275	A-Ø22/Ø27/R15	8	0
	W14x30	480/70 R 30	30168*	150.1	203.2	Ø19	8	inset 24
			30169	150.2	200	Ø17	8	inset 120.5
	W14Lx30	480/70 R 30	30141*	150.8	200	Ø17	8	inset 100
			30171	221	275	B2	8	inset -15
	DW14X30	480/70 R 30	30147*	152.4	203.2	B-Ø19/Ø27/90°	8	inset 126.6
			30168*	150.1	203.2	Ø19	8	inset 24
	DW14LX30	480/70 R 30	30172	281	335	B3	10	inset 50
			30160*	152.4	203.2	B-Ø19/Ø25/90°	8	inset 131
	DWW15Lx30	480/70 R 30	30161	101.701	165.1	B-Ø32.1/Ø26.9/ R22.2	6	inset 203.7
DW18Lx30	600/70R30 540/65R30	30508	221	275	A2	8	0	
		30517*	152.2	203.2	Ø19,8	8	0	
		30526*	152.4	203.2	Ø19	8	52	
30.5"	30.5xAG 20.00 H2	650/65 - 30,5 620/60 B 30,5 710/50 R 30,5	200312	281	335	A3	10	0
			200314	281	335	A3	10	inset -100
			200315	281	335	B3	10	inset -50
			200337	281	335	A3	10	inset -75
	30.5xAG 24.00 H2	750/60 - 30,5 710/50 - 30,5 750/60 R 30,5 800/45 R 30,5	240317	281	335	A3	10	inset -50
			240221	281	335	A3	10	0
			240339	281	335	B3	10	inset 90
			240350	281	335	B3	10	inset -25
	30.5xAG 28.00 H2	850/50 - 30,5 850/45 B 30,5 800/45 R 30,5 800/45 - 30,5 850/50 R 30,5	280312	281	335	A3	10	0
			280313	281	335	A3	10	inset -50
			280323	371	425	Ø25.4	12	inset -25
			280337	221	285.75	Ø20.6	10	0
			280344	220	287.75	Ø21	10	inset -28

Not all items are listed in this catalog. Please contact us for any application that you do not see in this catalog.
*Marked part numbers are Adjustable Wheels.

AGRICULTURAL and MULTI-PURPOSE WHEELS

RIM DIAMETER	WHEEL SIZE	TIRE SIZE	JANTSA PART NUMBER	CENTER HOLE (mm)	P.C.D. (mm)	HOLE TYPE (mm)	NUMBER OF BOLT HOLES	OFFSET (mm)
32"	W8x32	270/80R32	32804*	145	190	B-Ø20/Ø25/90°	8	inset 170
			32806	180	230	B-Ø20/Ø25/90°	6	inset -79.5
			32816	161	205	A2	6	inset 22
			32824 V-TRAC	390	430	Ø16.4	12	inset 60
	DW21Bx32	680/85R32 710/75R32 680/70R32 24,5R32	21321	281	335	A3	10	inset -50
			21322	221	275	Ø24	8	0
			21324	281	335	B3	10	0
			21331	281	335	B3	10	70
			21334	281	335	Ø24	10	inset 60
			21337	281	335	A3	10	inset -100
	DW27Bx32	900/70R32 800/70R32 850/60R32 900/55R32	27320	281	335	A3	10	0
			27324	281	335	Ø20.6	10	inset 38
			27331	281	335	B3	10	0
			27333	281	335	B3	10	inset -50
			27348	221	285.75	Ø20.6	10	0
			27367	281	335	A3	10	100
DW30Bx32	900/70 R32 900/55 R32	30322	281	335	Ø24	10	0	
DW36x32	1050/50R32	36320*	221	275	Ø26	16	inset 11	
34"	W15Lx34	480/70 R 34 520/70 R 34	34162*	221	275	Ø24	8	inset 80
			34164*	152.4	203.2	Ø19.5	8	92
			34170	152.6	203.2	Ø19.8	8	inset -60
			34178	221	275	A-Ø21/Ø27/R16	8	inset -100
			34185	152.4	203.2	B2	8	inset -130
			34193*	150.1	203.2	Ø19.8	8	inset -170
	DW15Lx34	480/70 R 34 520/70 R 34	34179	149.7	203.2	Ø19.8	8	inset 186
			34180	149.7	203.2	Ø19.8	8	36
DWW15Lx34	520/70 R 34	34157	150.1	203.2	Ø19.8	8	51	
36"	W8x36	270/95 R 36 230/95 R 36 270/80 R 36	36806	161	205	A2	6	50
			36808*	161	205	A2	6	0
			36809 V-TRAC	390	430	Ø16.4	12	inset 60
	W9x36	320/85R36 270/80R36 12,4R36	36903*	152.4	203.2	B1	8	55.2
	W11x36	340/85R36 320/85R36 13,6R36	36111*	152.4	203.2	B1	8	30
W11Lx36	340/85R36 320/85R36 13,6R36	36135*	150.8	203.2	Ø19	8	inset 116	
W12x36	13,6-36	36502*	152,4	203.2	B-Ø19/Ø26,9/90°	8	inset 112.5	

Not all items are listed in this catalog. Please contact us for any application that you do not see in this catalog.
*Marked part numbers are Adjustable Wheels.



AGRICULTURAL and MULTI-PURPOSE WHEELS

RIM DIAMETER	WHEEL SIZE	TIRE SIZE	JANTSA PART NUMBER	CENTER HOLE (mm)	P.C.D. (mm)	HOLE TYPE (mm)	NUMBER OF BOLT HOLES	OFFSET (mm)		
38"	DW10x38	11.2-38	10385	152.4	203.2	B-Ø21/Ø28,4/110°	8	38		
			10386	221	275	B3	8	38		
			10388*	150.1	203.2	Ø19	8	55		
			10391 V-TRAC	390	430	Ø16.4	12	inset 80		
	DW11x38	320/85R38	38503*	152.4	203.2	B1	8	76		
			38514	199	250	A-Ø24/Ø30/90°	8	inset 113		
			38126*	152.4	203.2	B-Ø19/Ø26.9/90°	8	inset 155.6		
	DW12x38	380/80R38	38313	221	285.75	Ø20.6	10	0		
			38317 V-TRAC	390	430	Ø16.4	12	inset 60		
			38306*	149.7	203.2	Ø19.8	8	162		
	DW12Lx38	380/80R38	38140*	152.4	203.2	B-Ø19/Ø26.9/90°	8	inset 115		
			38143	281	335	A3	10	0		
			38153*	199	250	B-Ø24/Ø30/90°	8	inset 173		
	DW15Lx38		15380	149.7	203.2	Ø19.8	8	36		
			15381	149.7	203.2	Ø19.8	8	36		
	DW16x38	520/70R38	16383*	152.4	203.2	A2	8	inset -130		
	DW16Lx38	520/85 R38	16387	281	335	Ø24	10	inset 100		
	DW18x38	COMING SOON...								
DW20x38	COMING SOON...									
MW23Bx38	710/70 R38 650/60 R38	23382	281	335	A3	10	0			
		23383	281	335	A3	10	inset -50			
		25380	613,5	662	Ø22	20	67.5			
MW25Bx38	710/70R38	42800	199.5	250	B-Ø24/Ø28/90°	8	inset 125			
		42801	161	205	B2	6	95			
42"	W8x42	270/95R42 230/95R42	42803 V-TRAC	390	430	Ø16.4	12	inset 62		
			MW23Bx42	650/85R42 710/70R42	23420	613,5	662	Ø22	20	108
			MW25Bx42	COMING SOON...						
44"	W8x44	9.5R44	44802	150.1	203.2	Ø19	8	inset 101.4		
			44808	221	275	B2	8	inset 83		
			44818*	152.4	203.2	Ø21	8	inset 101.4		
			44823 V-TRAC	390	430	Ø16.4	12	inset -162		
			44100 V-TRAC	390	430	Ø16.4	12	inset 62		
W10x44	270/95 R44	44120 V-TRAC	390	430	Ø16.4	12	inset 62			
46"	W10x46	300/95 R46 270/95 R46 320/90 R46	46100 V-TRAC	390	430	Ø16.4	12	inset 62		
			46120 V-TRAC	390	430	Ø16.4	12	inset 62		
			46130 V-TRAC	390	430	Ø16.4	12	inset 62		
48"	W8x48	270/95 R 48	48801*	152.4	203.2	Ø19.8	8	inset 120		
			48812 V-TRAC	390	430	Ø16.4	12	inset 62		
			48100 V-TRAC	390	430	Ø16.4	12	inset 62		
50"	W10x50	320/90 R50	50200 V-TRAC	390	430	Ø16.4	12	inset 62		
			50250 V-TRAC	390	430	Ø16.4	12	inset 62		
			52800 V-TRAC	390	430	Ø16.4	12	inset 62		
52"	W10x52	300/95 R 52	52101 V-TRAC	390	430	Ø16.4	12	inset 62		
			52120 V-TRAC	390	430	Ø16.4	12	inset 62		
			54100 V-TRAC	390	430	Ø16.4	12	inset 62		
54"	W12x54	380/90 R 54	54121 V-TRAC	390	430	Ø16.4	12	inset 62		

Not all items are listed in this catalog. Please contact us for any application that you do not see in this catalog.
*Marked part numbers are Adjustable Wheels.

V-TRAC MULTI-PIECE VARIOUS TRACK WHEELS

JANTSA presents a new range of narrow adjustable wheels for tractors and agricultural machinery.

Thanks to the 3-piece design these wheels can be easily applied for different machines with various hub and track requirements. Adjustable Disc plate and interchangeable Adaptor Flange assure robust solution for versatile agricultural applications.

- From 32" to 54" diameters
- User-friendly design and mounting
- 16 to 32 track options
- E-coating and more than 200 different top coat options
- Interchangeable adaptor flange with different PCD options
- Continuously welded ring for solid disc-rim connection

AVAILABLE SIZES				
RIM DIAMETER	8	10	12	13
32"	32824			
36"	36809			
38"		10391	38317	
42"	42803			
44"	44823	44100	44120	
46"		46100	46120	46130
48"	48812	48100	48120	
50"		50200	50250	
52"	52800	52120	52101	
54"		54100	54121	



ADAPTOR FLANGE OPTIONS			
PART NUMBER	NUMBER OF BOLT HOLES	CENTER HOLE	HOLE DETAILS
02479	8	290	18
02548	8	221	24
02550	10	281	27/32/R18 (A3)
02562	8	150,1	19,8
02565	8	152,4	19,8
02566	8	221	19,8
02567	8	139,7	21
02568	8	152,4	21
02577	8	152,4	19/24/R14 (B-)
02580	8	221	21
02632	0	40	0

CROWN-TRAC

JANTSA is one of the few worldwide manufacturers capable to produce crown wheels with 8 different track options which is the most modern. This is the most design of adjustable wheels preferred by major tractor manufacturers.

CROWN-TRAC EXPLODED

CONVENIENCE

8 standard wheel offset positions, easy and quick track changing guaranteed.

HIGHER SPEED

Designed for high horse power tractors operating at speed up to 65 km/h.

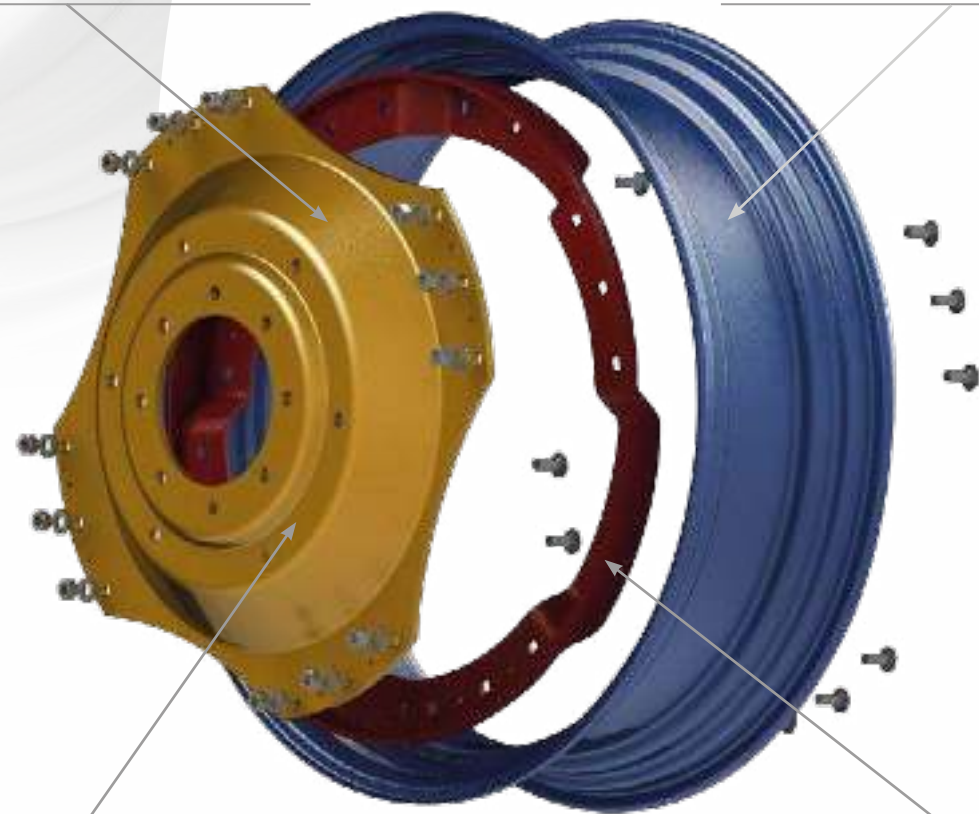

VARIETY

As of today we are capable to produce 22 wheel sizes in Crown-Trac design. More sizes are coming within the next months!

HIGHER LOAD CAPACITY

The disc is connected to the rim with a continuous welded crown ring which assures higher load capacity compared to standart adjustable wheels.

CROWN-TRAC ZOOM IN



AVAILABLE SIZES

28" DIAMETER	38" DIAMETER
W 9X28	DW 10X38
W 10X28	DW 11X38
W 11X28	DW 12X38
W 11LX28	DW 12LX38
W 12X28	DW 14X38
W 13X28	DW 16X38
W 13LX28	DW 18X38
W 14LX28	DW 20X38
W 15LX28	38XMW 23B
W 16LX28	38XMW 25B
DW 18LX28	

CROWN-TRAC WITH COLOR



Crown-Trac wheels in 24", 30",34" and 42" will be available shortly

As one of the fastest growing companies in the industry, JANTSA ,s committed to continuous improvement and innovation. Our creavity and entrepreneurial spirid are the basis for best-selling products which exceeds the industry requirements. Look out for more product introductions coming from JANTSA soon!





MAIN DEFINITIONS

The terms "Rim", "Disc" and "Wheel" are often confused in daily life. In order to save time and omit any mistakes, it is important to understand the difference between these definitions.

Wheel is a rotating component of the vehicle, which carries load of the car and passes the torque. The wheel is located between tire and hub. Most of the wheels manufactured by JANTSA are **Disc Wheels**, which consist of rim and disc assembled together. JANTSA is also manufacturing **Demountable Rims** (discless wheels / spoke wheels) with adapter ring, spokes, and clamps serving as a connection part of rim to the hub.

Disc serves as a connection part between wheel and hub (break drum/disc brake) of the vehicle and is either welded or connected with bolts to the rim.

Rim is a part of the wheel which serves as seat for the tire. According to standard JANTSA practice, all rim sizes are given in inches, which define **width** and **diameter** of the rim.

Rims, manufactured by JANTSA can be classified according to the **flange design** and angle of the tire bead seat. In terms of the flange design one can distinguish between two groups of rims: multi-piece and single-piece rims.

- **Single-piece** rims have one-piece rim design, with both flanges being integral parts of the rim.
- **Multi-piece** rims consist of rim itself and rings, which serve as demountable flange (s).

The type of rim can be easily identified in JANTSA catalogue by sign between measuring dimensions in inches:

- "x" – for single-piece rims (22.5x11.75, 9.00x15.3 etc.)
- "-" – for multi-piece rims (8.5-20; 17.00-25/1.7 etc.)



RIM PROFILES

JANTSA rim profiles can be classified into two groups:

- 15° bead seat angle rims for tubeless tires
- 5° bead seat angle rims for tubeless and tube-type tires

These rim profiles can be easily identified by the rim diameter:

- 15° - rims with diameter ending with 0,5" (15.5", 17.5", 22.5", 26.5", etc.)
- 5° - rims with all remaining diameters (15.3", 20", 24", 34", etc.)

The rim profiles, manufactured by JANTSA can be further classified in line with the scheme below.

RIM PROFILES PER BEAD SEAT ANGLE

15° BEAD SEAT ANGLE

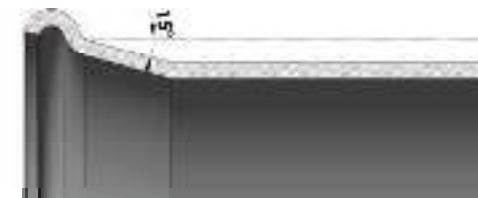

- Drop centre, symmetric
- Drop centre, asymmetric

5° BEAD SEAT ANGLE

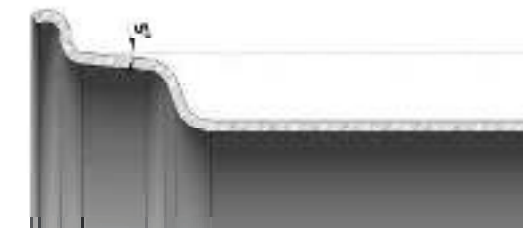

- W-Profile (single well)
- DW-Profile (double well)
- DWW-Profile (double well wide base)
- TW-Profile (triple well)
- MW-Profile
- Drop centre
- Multi-piece tapered bead seat
- Multi-piece flat base
- Multi-piece semi drop centre

WHEEL SPECIFICATIONS

AA-SECTION

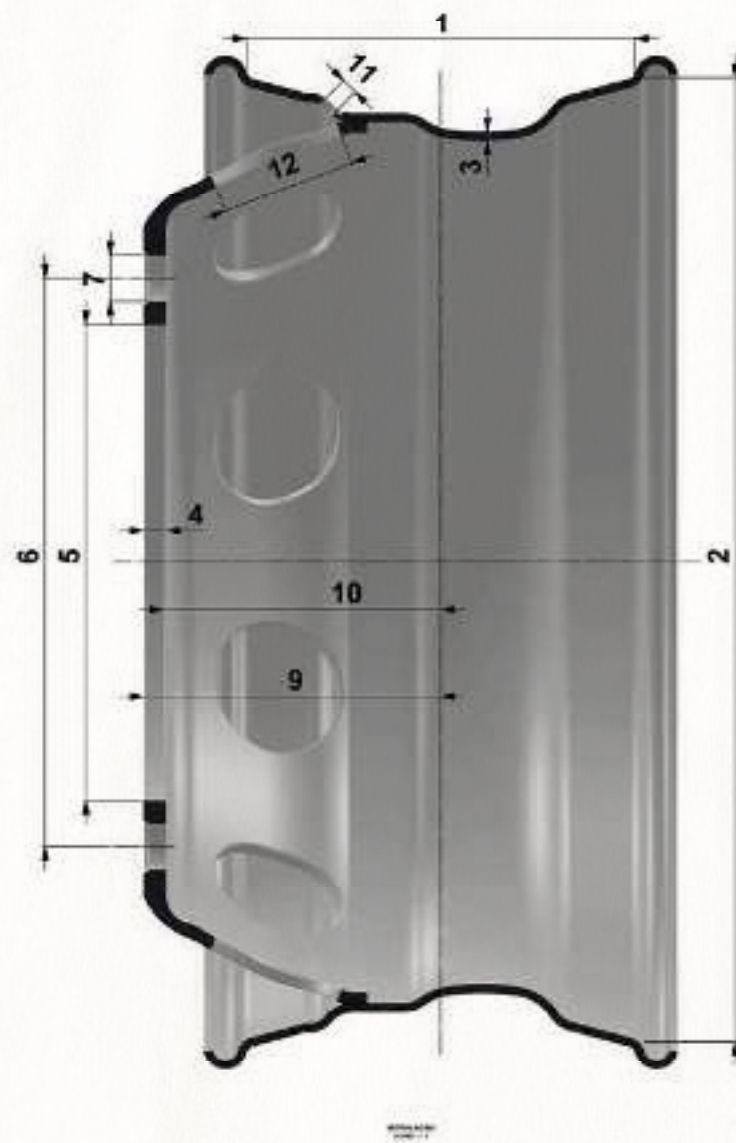

- | | |
|-------------------------------|---------------------------------|
| 1 Width of rim | 4 Thickness of disc material |
| 2 Diameter of rim | 5 Center hole diameter |
| 3 Thickness of rim material | 6 PCD (Pitch Circle Diameter) |

The secure fastening of wheel and effective load transmission is determined by exact matching of wheel and vehicle parts (axle hub and brake). Therefore, it is important to understand the key geometrical specifications of the wheel disc.

FRONT VIEW



- | | |
|--------------------------------|--------------------------------|
| 7 Bolt hole diameter | 10 Offset ET (Inset) |
| 8 Countersink diameter | 11 Valve hole diameter |
| 9 Offset (Half Dual Spacing) | 12 Ventilation hole diameter |

HOLE TYPE

FOR HUB CENTERED WHEELS

M 14	Ø 18.5	M 14 x 1.5
M 18	Ø 21	M 18 x 1.5
M 20	Ø 24	M 20 x 1.5
M 22	Ø 26	M 22 x 1.5

TYPE A

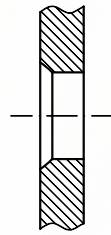

TYPE B

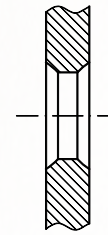

SPHERICAL / CONICAL STUD HOLE

M	B	STUD DIAMETER	I	E	S	C	DIAMETER ANGLE
Hub Centring	Bolt Centring	22	Inside	External	Spherical	Conical	36



HOLE TYPE

COUNTERSINK TYPE

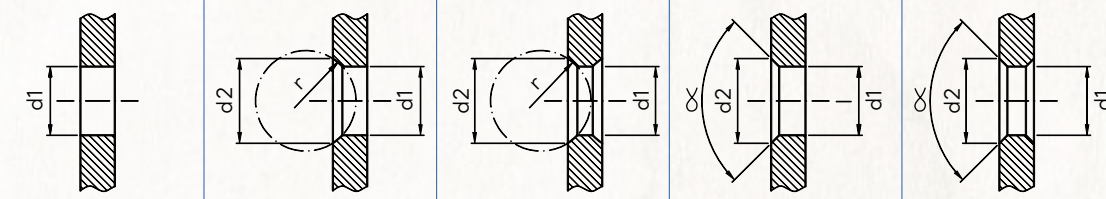

STRAIGHT

SPHERICAL
(TYPE A)

SPHERICAL
(TYPE B)

CONICAL
(TYPE A)

CONICAL
(TYPE B)

SPHERICAL COUNTERSINK

JANTSA STANDARD	d1 (Ø)	d2 (Ø)	r	ACCORDING TO EUWA	THREAD
A1-B1	18.5	24	14	B14 ES 28 / B14 DS 28	M14X1.5
A2-B2	21.5	27	16	B18 ES 32 / B18 DS 32	M18X1.5
A3-B3	27	32	18	B22 ES 36 / B22 DS 36	M22X1.5
A4-B4	20.5	25	14		
A5-B5	32.15	37	22.2	B19 ES 44.4 / B19 DS 44.4	3/4" UNF Thread
A6-B6	14	-	14	-	-
A7-B7	15.5	-	14	-	-
A8-B8	18.5	-	14	-	-
A9-B9	20	-	14	-	-
A10-B10	21	-	14	-	-
A11-B11	20	-	12	-	-
A12-B12	16	20	13	-	-
A26-B26	15	20	13	-	-
A31-B31	37	43	25	-	-
A33-B33	26	32	18	M22 ES 36 / M22 DS 36	M22X1.5
A34-B34	29	34	22	-	-

CONICAL COUNTERSINK

JANTSA STANDARD	d1 (Ø)	d2 (Ø)	α	ACCORDING TO EUWA	THREAD
A13-B13	14	19.8	60°		
A14-B14	16	19.8	60°		
A15-B15	16	22	90°		
A16-B16	14.2	-	60°		
A17-B17	25.4	31.5	80°	B23 EC 80 / B23 DC 80	7/8" UNF Thread
A18-B18	18.5	-	60°		
A19-B19	16.8	-	60°		
A20-B20	28.6	36	90°		
A21-B21	21.5	27	90°		
A22-B22	12	-	80°		
A23-B23	-	17	60°		
A24-B24	13	16	90°		
A25-B25	10.5	-	60°		
A37-B37	26	31.5	80°	M23 EC 80/M23 DC 80	7/8" UNF Thread
A38-B38	16.3	-	90°		



WHEEL CENTERING

The common types of mounting systems are Stud centered, Hub centered, and Double centered.

Stud centered system uses the studs on the wheel hub to guide and center the wheel. Chamfered stud holes identify a stud centered wheel. These wheels are designed to be centered by conical or spherical nuts on the studs.

Hub centered systems use the actual wheel hub to guide and center the wheel. Hub centered wheels generally have straight bolt holes with no ball seat for nuts with flat washer (flange nuts). These wheels require narrow tolerance of center hole dimensions.

Double centered mounting systems use both wheel hub and studs to center the wheel. These wheels have bolt holes with countersinks together with center hole with a narrow tolerance. They mostly use spherical or conical nuts, but flange nuts like for hub-centered wheels can be also used.

It is imperative to use right components for each type of mounting and to fit wheels to the proper hubs. Mixing components of different mounting systems can lead to breaking of studs, decrease of torque, cracks on wheels and eventually wheel slippage.

STUD CENTERED WHEEL

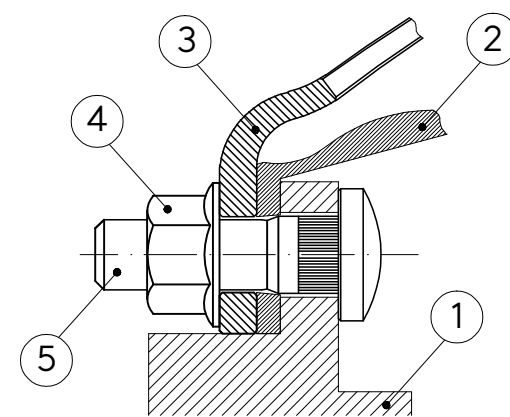

HUB CENTERED WHEEL

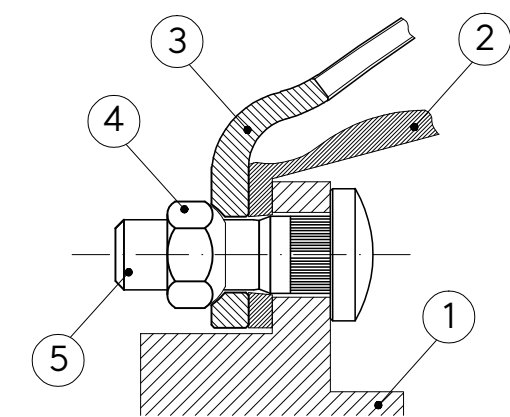

- 1 | Hub 2 | Drum 3 | Disc 4 | Nut 5 | Bolt

OFFSET

One of the crucial dimensions of the disc wheel is Offset. As per **JANTSA** classification offset is a dimension from imaginary rim center line to outer disc surface. For dual mounting applications Offset equals to "half dual spacing". Dual spacing is a distance between center lines of two imaginary rims in dual mounting. Values of track width, tire clearance, overall vehicle width of tires, and in some cases overall vehicle width are determined by dual spacing. Therefore, values of minimum dual spacing are regulated by several standards, including **ETRTO** and **TR&A**.

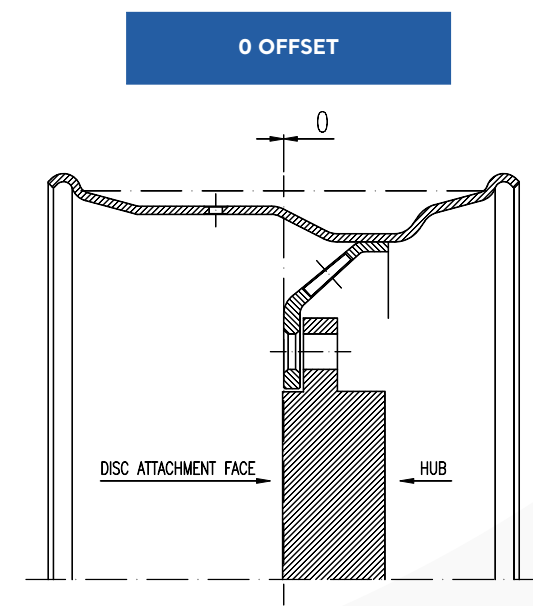
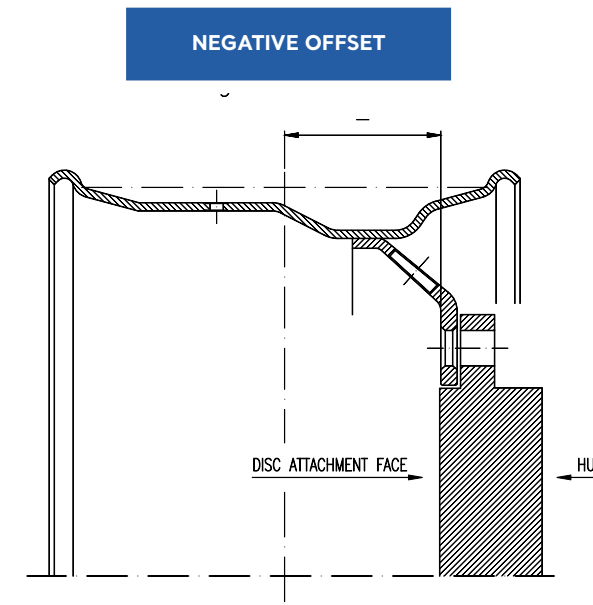
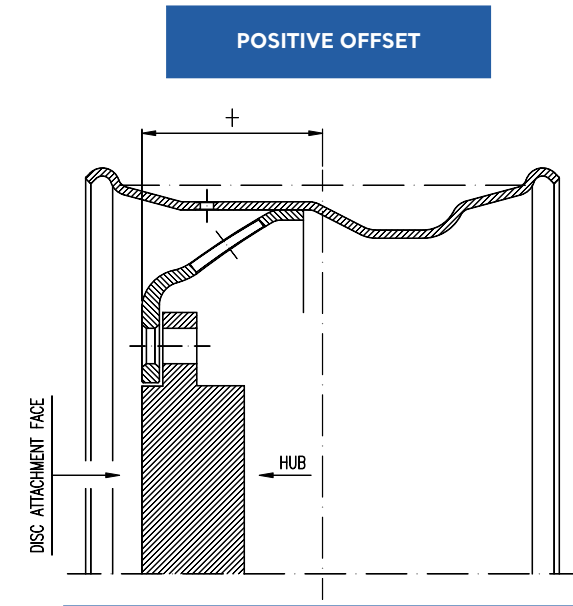
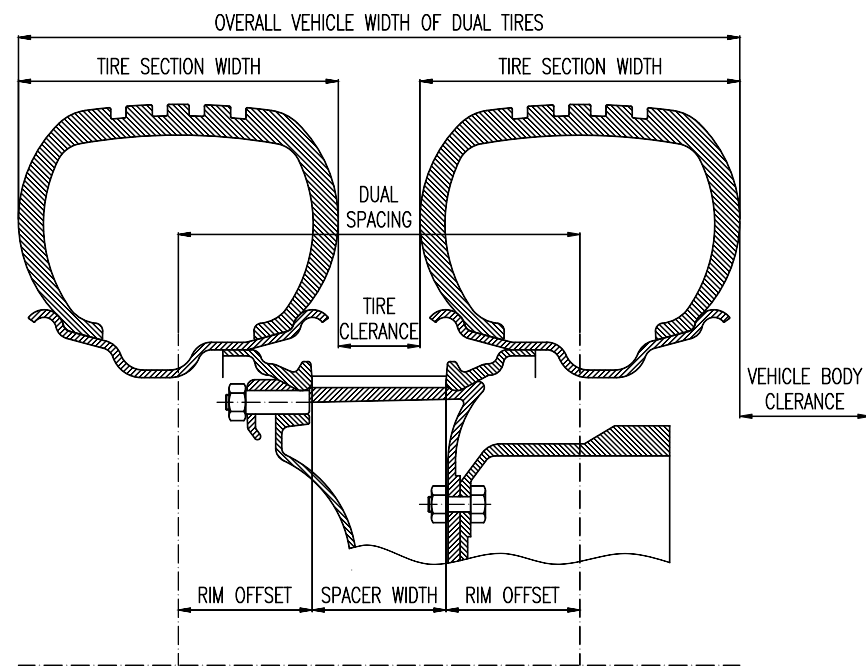
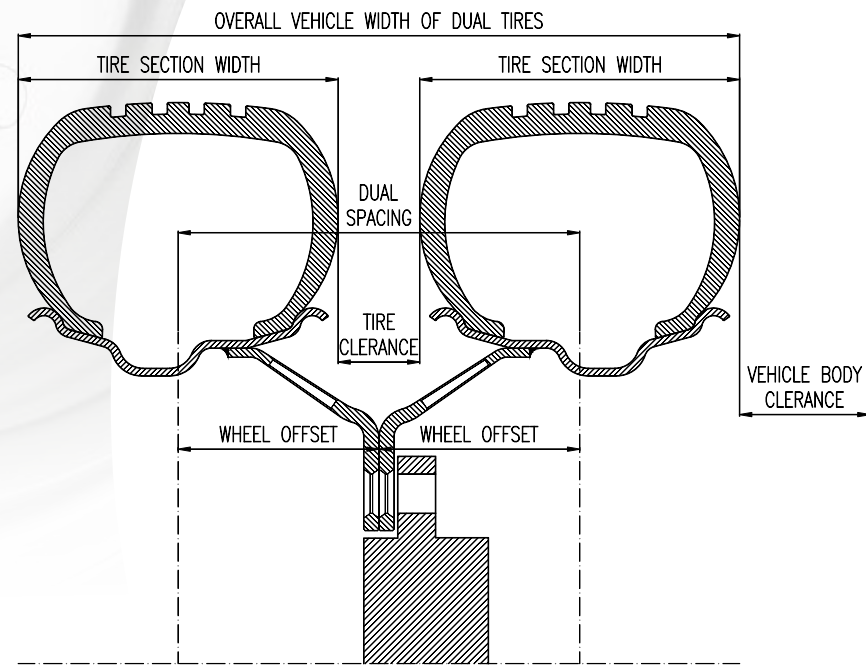

Another measurement, commonly used by many manufacturers is **Offset ET** (from German "Einpresstiefe" or so-called "Inset"), which is a dimension from imaginary rim center line to inner disc attachment surface. Difference between value of Offset and Offset ET equals disc thickness of the wheel.

Disc wheel offset can be positive, negative or so-called "0-offset":

- **Positive Offset:** the disc-hub attachment face is located at the outer side of the rim
- **Negative Offset:** the disc-hub attachment face is located at the inner side of the rim
- **"0-offset":** the disc-hub attachment face is located at the center of the rim

LOAD CAPACITY

In addition to the geometrical construction specifications, each wheel is designed for a specific **load carrying capacity** and corresponding **speed**.

Load capacity or **load rating** is defined as the the maximum load a wheel is permitted to carry at the specific speed and under certain operating conditions. Do not to load and inflate the tyre / wheel / axle system beyond the rating of the lowest rated component. Thus, wheel load and cold inflation pressure imposed on the wheel may not exceed JANTSA's recommendations and the load permitted by the vehicle manufacturer, even though the tyre may be approved for a higher load or inflation pressure. If you do not have information about the tire load capacity and inflation rating, please contact the tire manufacturer or distributor. Similarly, the identified wheel load shall not be exceeded, even if the speed index is decreased.

Speed indicates the maximum speed at which the wheel can carry a load corresponding to its Load Capacity under service conditions specified by the wheel manufacturer.

SPEED SYMBOL CODE	SPEED VITESSE (KM/H)
A1	5
A2	10
A3	15
A4	20
A5	25
A6	30
A7	35
A8	40
B	50
C	60
D	65
E	70
F	80
G	90
J	100
K	110
L	120
M	130
N	140
P	150
Q	160

WARNING

- The wheel may break under excessive load, causing tire failure and sever injuries. Please refer to the Gross Axle Wheel Rating (GAWR), which is provided by the vehicle or machine manufacturer, when in doubt.
- Load carrying capacity and speed, which are provided in this catalogue, indicate only reference values for standard applications. In case of any doubt about the suitability of JANTSA wheels for specific tire or usage, please consult our technical support.

The load capacity and speed of a wheel or tire are expressed by ETRTO indices.

LOAD INDEX

LI	kg
80	450
81	462
82	475
83	487
84	500
85	515
86	530
87	545
88	560
89	580
90	600
91	615
92	630
93	650
94	670
95	690
96	710
97	730
98	750
99	775
100	800
101	825
102	850
103	875
104	900
105	925
106	950
107	975
108	1000
109	1030
110	1060
111	1090
112	1120
113	1150
114	1180
115	1215
116	1250
117	1285
118	1320
119	1360
120	1400
121	1450
122	1500
123	1550
124	1600
125	1650
126	1700
127	1750
128	1800
129	1850
130	1900

LI	kg
130	1900
131	1950
132	2000
133	2060
134	2120
135	2180
136	2240
137	2300
138	2360
139	2430
140	2500
141	2575
142	2650
143	2725
144	2800
145	2900
146	3000
147	3075
148	3150
149	3250
150	3350
151	3450
152	3550
153	3650
154	3750
155	3875
156	4000
157	4125
158	4250
159	4375
160	4500
161	4625
162	4750
163	4875
164	5000
165	5150
166	5300
167	5450
168	5600
169	5800
170	6000
171	6150
172	6300
173	6500
174	6700
175	6900
176	7100
177	7300
178	7500
179	7750
180	8000

LI	kg
180	8000
181	8250
182	8500
183	8750
184	9000
185	9250
186	9500
187	9750
188	10000
189	10300
190	10600
191	10900
192	11200
193	11500
194	11800
195	12150
196	12500
197	12850
198	13200
199	13600
200	14000
201	14500
202	15000
203	15500
204	16000
205	16500
206	17000
207	17500
208	18000
209	18500
210	19000
211	19500
212	20000
213	20600
214	21200
215	21800
216	22400
217	23000
218	23600
219	24300
220	25000
221	25750
222	26500
223	27250
224	28000
225	29000
226	30000
227	30750
228	31500
229	32500



SURFACE TREATMENT

Wheel paint system is essential for the safety and performance of the vehicle. A superior coating not only assures great appearance, but also provides long rust protection against tough environmental and working conditions, which minimizes maintenance costs.

All JANTSA wheels receive a three-layer surface treatment that guarantees superior rust protection and premium look.

- **Zinc Phosphate Pre-Treatment:** Prepares metal for enhanced corrosion resistance and excellent paint adhesion.
- **Epoxy E-coat (cataphoresis):** Assures the best available surface protection, equally distributed on wheel surface. It is especially crucial for hard-to-reach areas, such as wheel sharp corners and edges, where rust tends to appear first (e.g. between disc and rim, holes, and rim flanges). In production, we are available to implement black or grey color options.
- **Wet Topcoat:** Premium paint, which prevents expansion of rust from scratches on the wheel metal. The flexible paint system allows application of virtually any color per customer demand.

JANTSA closely cooperates with the leading paint suppliers, while maintaining its coating know-how in house. Thus, four different top-coat variations (2K-acrylic, alkyd, polyester, 1K-acrylic) were developed exclusively for JANTSA needs. At the same time, two fully automated e-coating workshops with a joint annual capacity of 2 million wheels assure production efficiency with minimum ecological footprint.

Key advantages of JANTSA painting system are:

- **Utmost corrosion resistance** – an extended salt spray test period till 1500 hours and reduced corrosion on wheel corners and edges
- **Cost efficiency** – longer wheel life guarantees minimum maintenance costs
- **Appearance** – premium top coating with more than 200 standard colors available
- **Sustainability** – chemical materials used in surface treatment don't contain any materials which are listed in REACH Regulations.

In sum, JANTSA coating meets the strict requirements of automotive industry for durability and look in the toughest operating environment.

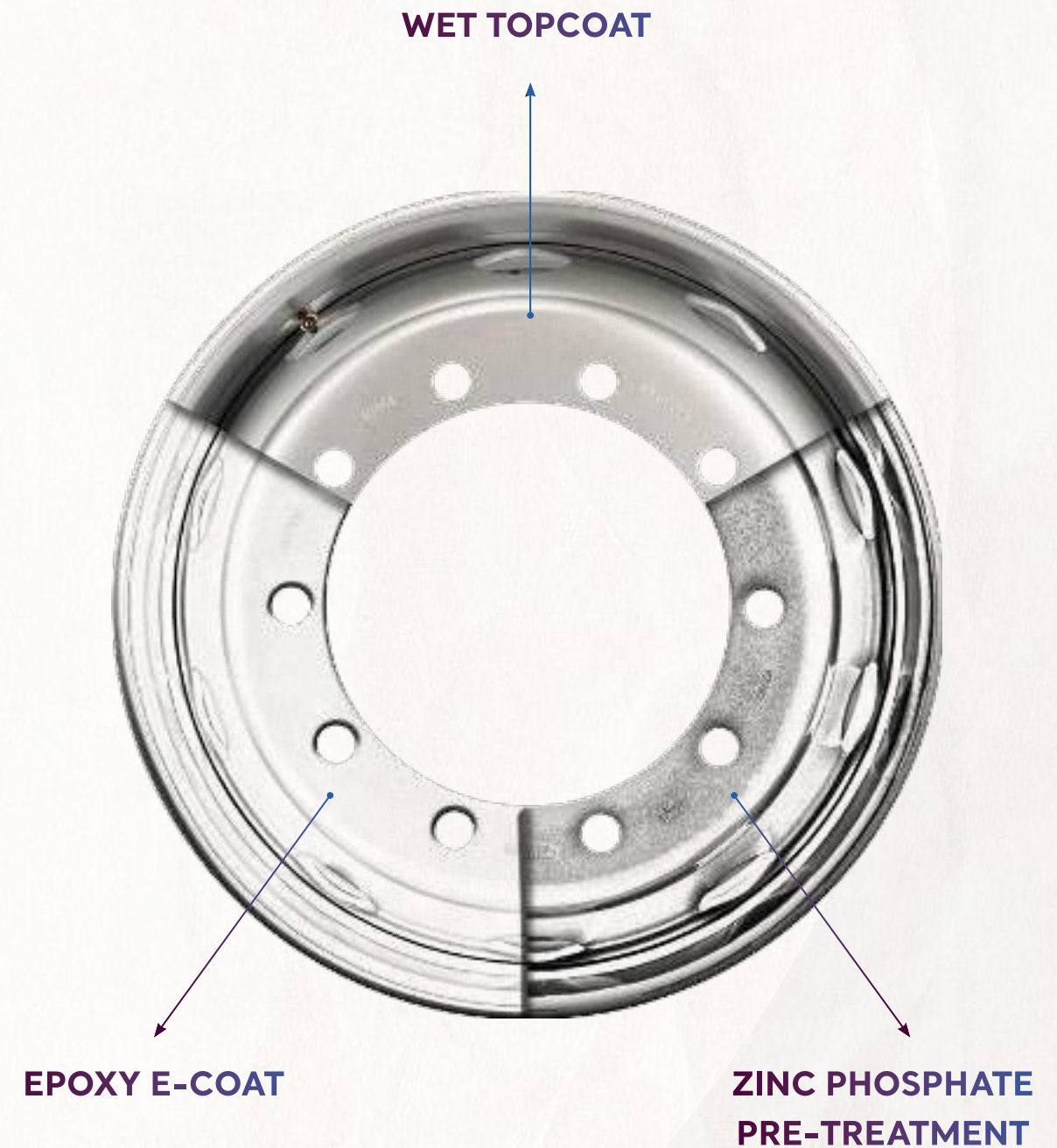

OFF-ROAD SOLUTIONS

There are several specific solutions, which JANTSA offers for the agricultural and industrial sector.

ADJUSTABLE WHEELS

Different agricultural crops require various tracks for the machinery running in the fields. An easy solution to this challenge is provided by wheels with adjustable offset value. Here, the disc is attached to the rim on lugs (ring) and bolts. Such design enables the user to adjust offset by changing the position of the disc.

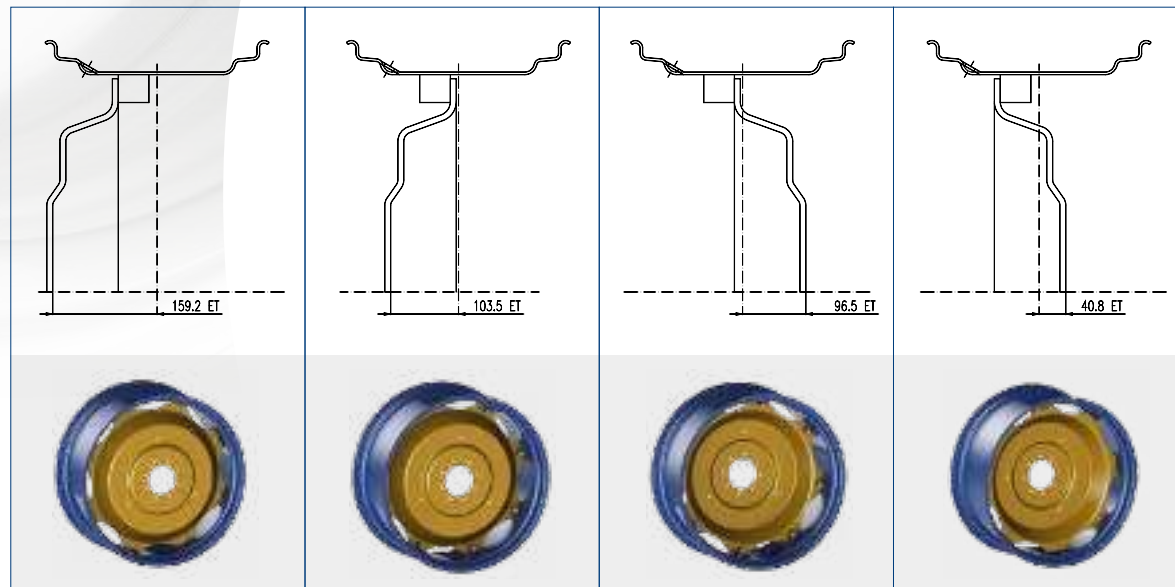

Depending on the application, there are different types of lugs / rings, with the most standard ones listed below.



KNURLING

Knurling is a pattern of straight lines (grooves) in the rim bead seat area, which prevents tire from slippage. It is typically applied on the bigger wheel sizes, which are exposed to strong traction and therefore require a better contact between rim and the tire.



VALVE PROTECTION AND REINFORCEMENT

Agricultural, forestry, and industrial machines frequently operate in tough conditions, which might expose wheels to impacts and stress. Valve guards are used to secure the valve from damaging for some off-road wheels.



Additionally, rims can be protected from impacts and stress by reinforcing the flange. Such measure is used for the toughest operating conditions.

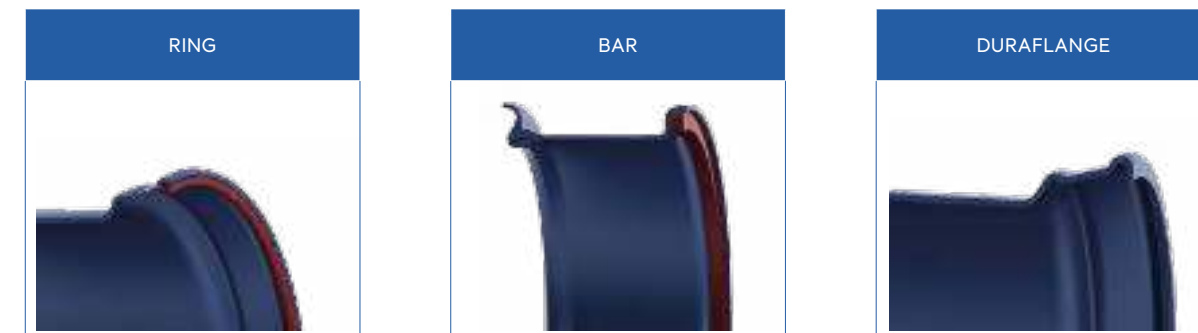

HUMPS

Hump is an extra bend on the rim profile, which ensures tight fitment of tire bead, while operating at low air pressure.

RINGS FOR MUTI-PIECE WHEELS

2 PIECE RIM

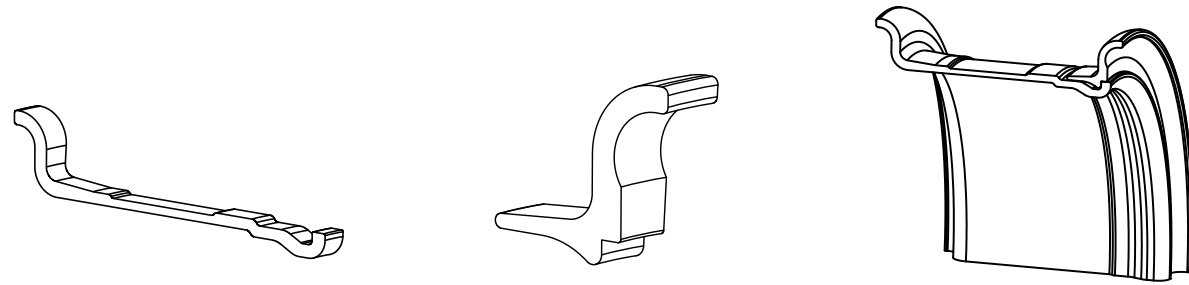

	RIM BASE	COMBINED RING	2 PIECES
	RIM BASE MARKINGS	COMBINED RING MARKINGS	
20"	Traceability Markings (7.0-20)	Jantsa-Size-CR-Month Year-Batch No (02008)	
	Traceability Markings (7.5-8.0/20)	Jantsa-Size-CR-Month Year-Batch No (01946)	
	Traceability Markings (8.5-20)	Jantsa-Size-CR-Month Year-Batch No (01116)	
24"	Traceability Markings (8.5-24)	Jantsa-Size-CR-Month Year-Batch No (01144)	

3 PIECE RIM

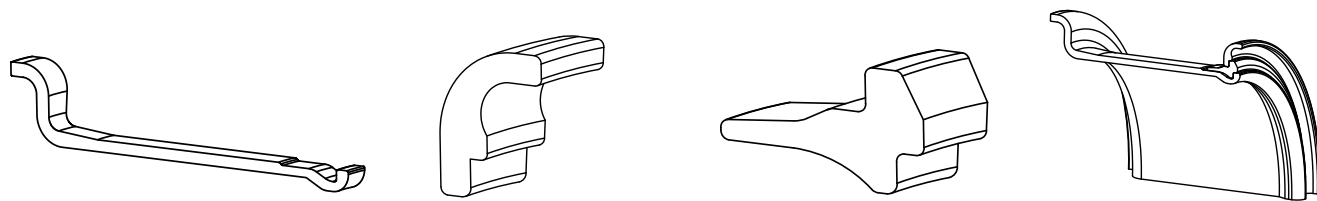

	RIM BASE	SIDE RING	LOCK RING	3 PIECE
	RIM BASE MARKINGS	SIDE RING MARKING	LOCK RING MARKINGS	NOTCHED LOCK RING MARKINGS
15"	Traceability Markings (6.0-6.50-7.0)	Jantsa-Size-SR-Month Year-Batch No (0828)	Jantsa-Size-LR-Month Year-Batch No (01607)	Jantsa-Size-LR-Month Year-Batch No (01096)
	Traceability Markings (7.5)	Jantsa-Size-SR-Month Year-Batch No (01111)	Jantsa-Size-LR-Month Year-Batch No (01607)	Jantsa-Size-LR-Month Year-Batch No (01096)
	Traceability Markings (8.0-8.5)	Jantsa-Size-SR-Month Year-Batch No (01112)	Jantsa-Size-LR-Month Year-Batch No (01607)	Jantsa-Size-LR-Month Year-Batch No (01096)
	Traceability Markings (9.75)	Jantsa-Size-SR-Month Year-Batch No (0828)	Jantsa-Size-LR-Month Year-Batch No (01607)	Jantsa-Size-LR-Month Year-Batch No (01096)
20"	Traceability Markings (6.0-6.50-7.0)	Jantsa-Size-SR-Month Year-Batch No (01110)	Jantsa-Size-LR-Month Year-Batch No (0759)	Jantsa-Size-LR-Month Year-Batch No (01093)
	Traceability Markings (7.5)	Jantsa-Size-SR-Month Year-Batch No (0758)	Jantsa-Size-LR-Month Year-Batch No (0759)	Jantsa-Size-LR-Month Year-Batch No (01093)
	Traceability Markings (8.0-8.5)	Jantsa-Size-SR-Month Year-Batch No (01113)	Jantsa-Size-LR-Month Year-Batch No (0759)	Jantsa-Size-LR-Month Year-Batch No (01093)
	Traceability Markings (9.0)	Jantsa-Size-SR-Month Year-Batch No (01113)	Jantsa-Size-LR-Month Year-Batch No (0759)	Jantsa-Size-LR-Month Year-Batch No (01093)
24"	Traceability Markings (10.00)	Jantsa-Size-SR-Month Year-Batch No (01113)	Jantsa-Size-LR-Month Year-Batch No (0759)	Jantsa-Size-LR-Month Year-Batch No (01093)
	Traceability Markings (11.00)	Jantsa-Size-SR-Month Year-Batch No (01113)	Jantsa-Size-LR-Month Year-Batch No (0759)	Jantsa-Size-LR-Month Year-Batch No (01093)
24"	Traceability Markings (8.0-8.5-10.00)	Jantsa-Size-SR-Month Year-Batch No (0789)	Jantsa-Size-LR-Month Year-Batch No (01115)	Jantsa-Size-LR-Month Year-Batch No (01065)

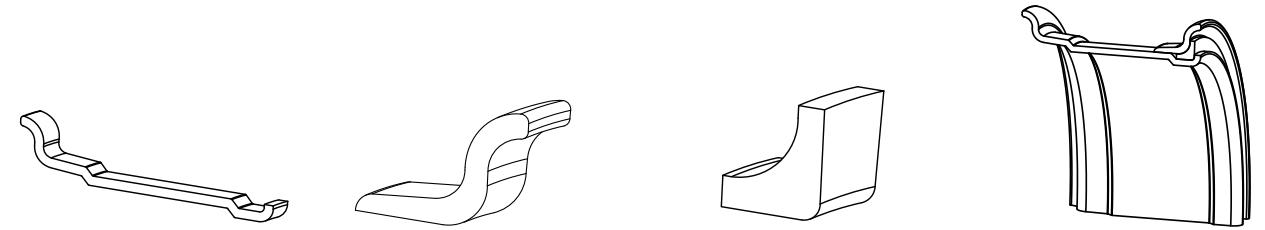

	RIM BASE	SIDE RING	LOCK RING	3 PIECE
	RIM BASE MARKINGS	SIDE RING MARKING	LOCK RING MARKINGS	
16"	Traceability Markings (6.50-16)	Jantsa-Size-SR-Month Year-Batch No (0369)	Jantsa-Size-LR-Month Year-Batch No (0371)	COMMERCIAL
	Traceability Markings (5.50-16)	Jantsa-Size-SR-Month Year-Batch No (0659)	Jantsa-Size-LR-Month Year-Batch No (0663)	AGRICULTURAL
	Traceability Markings (5.50-16)	Jantsa-Size-SR-Month Year-Batch No (0760)	Jantsa-Size-LR-Month Year-Batch No (0761)	COMMERCIAL
	Traceability Markings (5.50-16)	Jantsa-Size-SR-Month Year-Batch No (01673)	Jantsa-Size-LR-Month Year-Batch No (01671)	COMMERCIAL

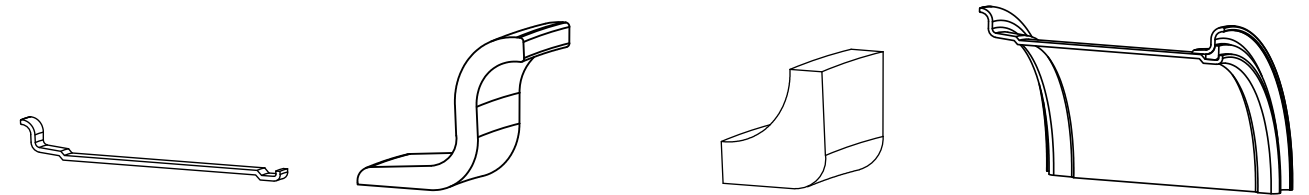

	RIM BASE	SIDE RING	LOCK RING	3 PIECE
	RIM BASE MARKINGS	SIDE RING MARKING	LOCK RING MARKINGS	
18"	Traceability Markings (13-18)	Jantsa-Size-SR-Month Year-Batch No (01373)	Jantsa-Size-LR-Month Year-Batch No (1276)	AGRICULTURAL

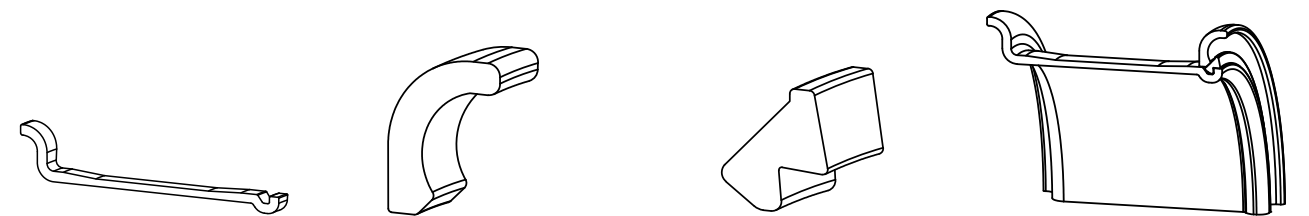

	RIM BASE	SIDE RING	LOCK RING	3 PIECE
	RIM BASE MARKINGS	SIDE RING MARKING	LOCK RING MARKINGS	NOTCHED LOCK RING MARKINGS
20"	Traceability Markings (10.00V-11.00V/20")	Jantsa-Size-SR-Month Year-Batch No (0975)	Jantsa-Size-LR-Month Year-Batch No (0974)	Jantsa-Size-LR-Month Year-Batch No (01375)
	Traceability Markings (10.00W/20")	Jantsa-Size-SR-Month Year-Batch No (01528)	Jantsa-Size-LR-Month Year-Batch No (0974)	Jantsa-Size-LR-Month Year-Batch No (01375)

RINGS FOR MUTI-PIECE WHEELS

3 PIECE RIM

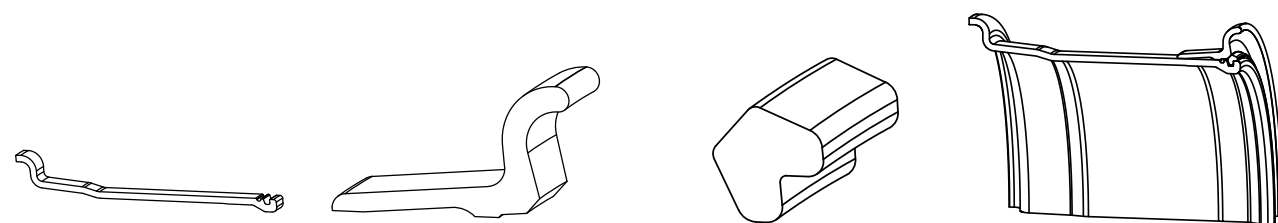

	RIM BASE	SIDE RING	LOCK RING	3 PIECE
	RIM BASE MARKINGS	SIDE RING MARKING	LOCK RING MARKINGS	
20"	Traceability Markings (11.00)	Jantsa-Size-SR-Month Year-Batch No (01204)	Jantsa-Size-LR-Month Year-Batch No (01609)	
	Traceability Markings (9.5-25/1.7)	Jantsa-Size-SR-Month Year-Batch No (01179)	Jantsa-Size-LR-Month Year-Batch No (01608)	
	Traceability Markings (10.00-25/1.5)	Jantsa-Size-SR-Month Year-Batch No (01141)	Jantsa-Size-LR-Month Year-Batch No (01608)	
25"	Traceability Markings (11.25-25/1.7)	Jantsa-Size-SR-Month Year-Batch No (01179)	Jantsa-Size-LR-Month Year-Batch No (01608)	
	Traceability Markings (12.00-25/1.3)	Jantsa-Size-SR-Month Year-Batch No (01224)	Jantsa-Size-LR-Month Year-Batch No (01608)	
	Traceability Markings (14.00-25/1.5)	Jantsa-Size-SR-Month Year-Batch No (01141)	Jantsa-Size-LR-Month Year-Batch No (01608)	
	Traceability Markings (17.00-25/1.7)	Jantsa-Size-SR-Month Year-Batch No (01179)	Jantsa-Size-LR-Month Year-Batch No (01608)	

5 PIECE RIM

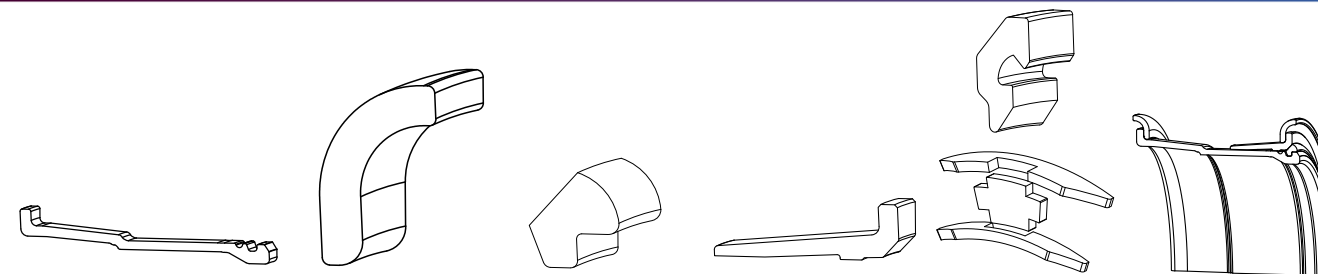

	RIM BASE	SIDE RING	LOCK RING	BEAD SEAT	DRIVER KEY	5 PIECE
	RIM BASE	SIDE RING	LOCK RING	BEAD SEAT	DRIVER KEY	
25"	25-11.25/2	01828	01830	01829-0111	01831-0112	
	25-13.00/2.5	01838				
	25-17.00/2	01328				
	25-19.50/2.5	01838				
	25-22.00/3	01840				
	25-25.00/3.5	01841				

4 PIECE RIM

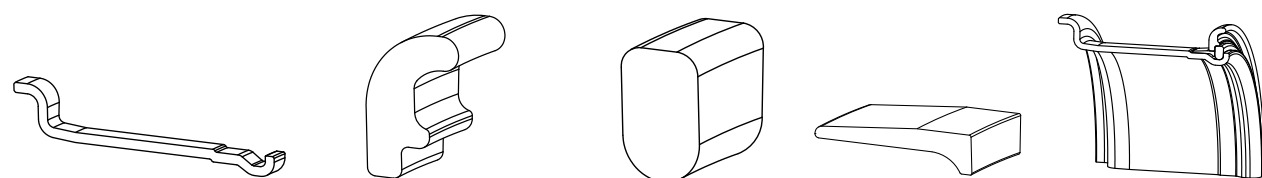

	RIM BASE	SIDE RING	SECURITY RING	CONICAL RING	4 PIECE
	RIM BASE MARKINGS	SIDE RING MARKING	SECURITY RING MARKINGS	CONICAL RING MARKINGS	
20"	Traceability Markings (10.0-20)	Jantsa-Size-24"-SR-Year (02486)	Jantsa-Size-24"-SR-Year (02496)	Jantsa-Size-24"-SR-Year (02488)	
24"	Traceability Markings (8.5-24)	Jantsa-Size-24"-SR-Year (01279)	Jantsa-Size-24"-SR-Year (01147)	Jantsa-Size-24"-SR-Year (01146)	
	Traceability Markings (10,00)	Jantsa-Size-SR-Month Year-Batch No (01145)	Jantsa-Size-24"-SR-Year (01147)	Jantsa-Size-24"-SR-Year (01146)	



JANTSA PRODUCT STAMPING

RIM

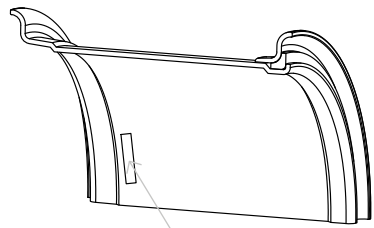

JANTSA / Label / Year / Week / Day / Shift / Lot No / Wheel Size / R
(Traceability Markings)

SIDE RING

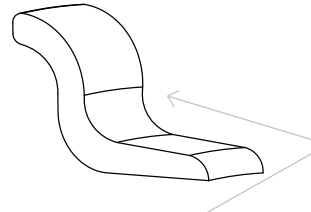

JANTSA - Size - SR - Year
(Traceability Markings)

LOCK RING

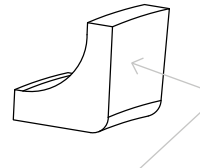

JANTSA - Size - LR - Year
(Traceability Markings)

COMBINE RING

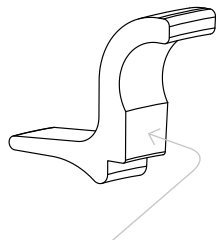

JANTSA - Size - CR - Year
(Traceability Markings)

CONICAL RING

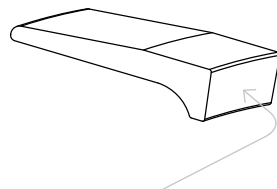

JANTSA - Size - CR - Year
(Traceability Markings)

LOCK RING

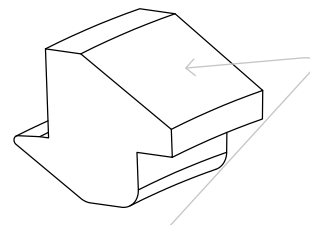

JANTSA - Size - LR - Year
(Traceability Markings)

SIZE RING

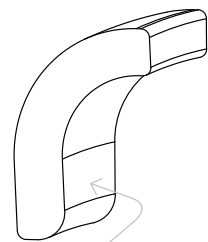

JANTSA - Size - SR - Year
(Traceability Markings)

LOCK RING

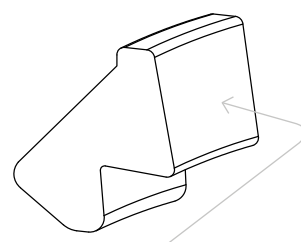

JANTSA - Size - LR - Year
(Traceability Markings)

SECURITY RING

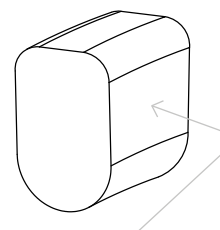

JANTSA - Size - SR - Year
(Traceability Markings)

DISC MARKING

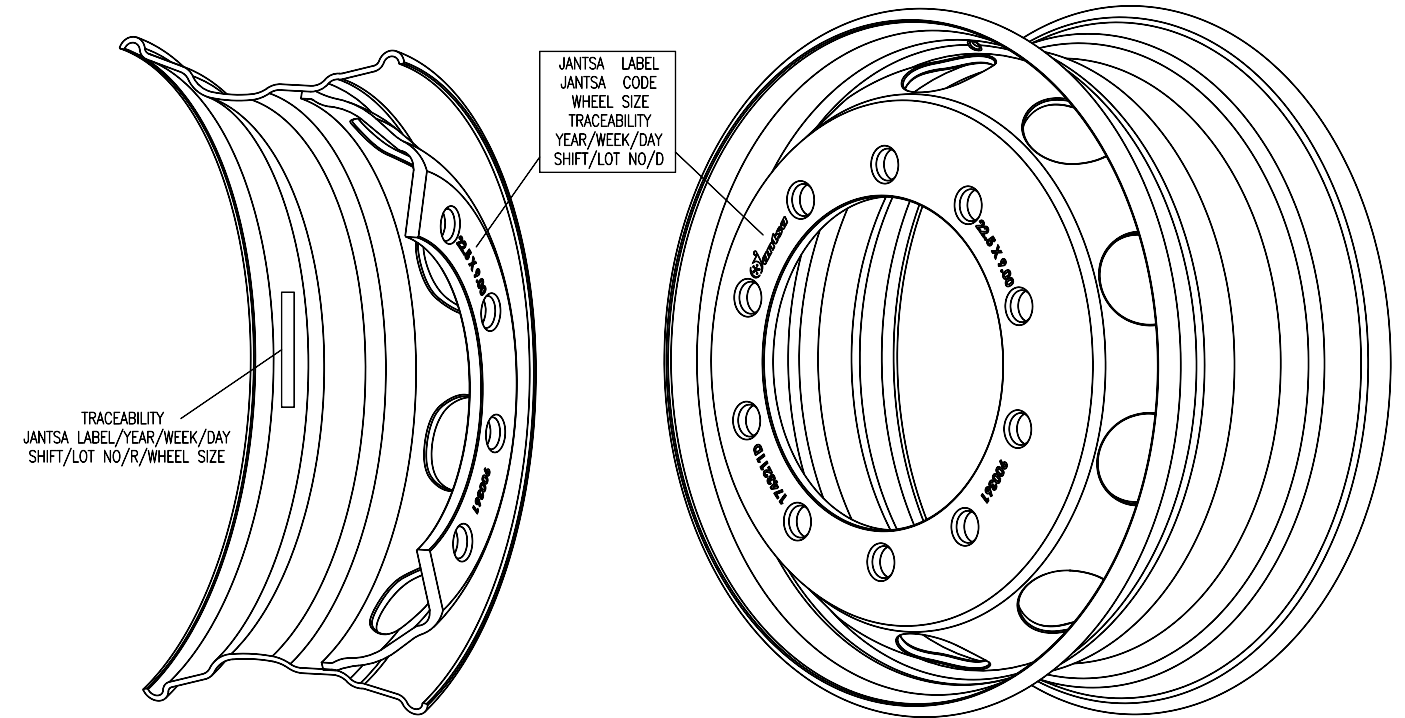

ECO-WHEELS!

We always respect the nature and environment with sustainable development at our facilities.

As JANTSA, we strictly pay attention to environmental aspects in each and every step we take for continuous improvement in our processes. We do not produce wheels only, but also produce our own electricity through our roof-top solar panels which generates 2 million watts electricity per year.

TECHNOLOGICAL

ECO-FRIENDLY

SUSTAINABLE

TOUGH

ATTRACTIVE

SAFETY & MOUNTING RECOMMENDATIONS

It is important to handle wheels with maximum care, and pay special attention to its safe usage, mounting, demounting and service. Users have to follow all conditions and norms according to industry, national and international regulations. As JANTSAs we will try to point out just those which we consider as the most common and important.

Before servicing, disc wheels have to be checked for following **possible damages**:

- Cracks on the disc and/or rim
- Asymmetric shape of disc contact surface
- Deformed (damage, burr, excessive corrosion etc) stud holes
- Deformed (damage, burr, excessive corrosion etc) flanges
- Excessive corrosion
- Excessive wear
- Damaged rings of multi-piece wheels

Using wheels/components under these conditions is strictly forbidden. Damaged parts should be replaced.

While **mounting the wheel on a hub** you have to ensure that all surfaces are clean, free from rust and deposits. Elements of different mounting types should not be confused, since this may result in loss of torque, disc surface cracks, bolts and studs damage, and loss of wheel. Applied torque level should correspond to instructions of vehicle manufacturer. Nuts installation has to be done crosswise, with gradual increase of torque level. Tightening of nuts on the wheel has to be checked 100 km after first installation and regularly during usage.

Examples of nut tightening sequence related to commercial vehicle disc wheels having 6, 8, 10 bolt fixing and to the TRILEX wheel system.

Mounting and Demounting of tire on the wheel has to be done by qualified personnel in well-equipped service points, according to specifications and procedures stipulated by ETRTO, TRA and other industry, national and international regulations. You have to ensure that all surfaces are clean, free from rust and deposits. It is crucial to match properly wheel and tire sizes according to above mentioned standards and recommendations of the vehicle manufacturer. Mismatch can result in serious damages and injuries. Diameter shown on the tire should exactly match the diameter stamped on the rim/wheel. Tires must be completely deflated before demounting wheel, or components of the wheel from the vehicle. Avoid standing in front of multi-piece wheels during assembly: damaged components might spring off.

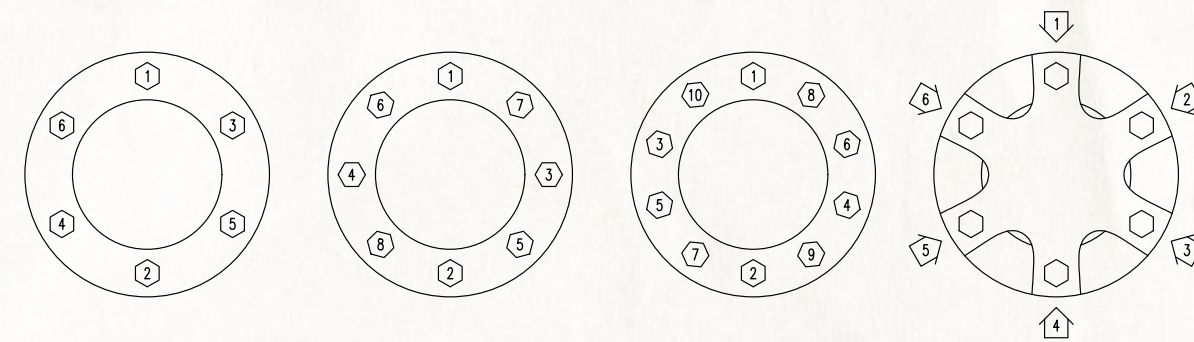

Mixing components of various manufactures may result in fatal injuries, therefore only matching parts of one manufacturer and one wheel system can be assembled.

Repair or of steel wheels is strictly prohibited. Especially dangerous is:

- Welding of rims or wheels
- Repair of damaged stud holes
- Repair of deformed center hole
- Straightening of disc contact surface
- Straightening of rim flanges

JANTSAs does not bear obligation under warranty for goods if they were modified, repaired or processed. This instruction should be used only as a guide and can not be the only source of information of safety information on wheels.

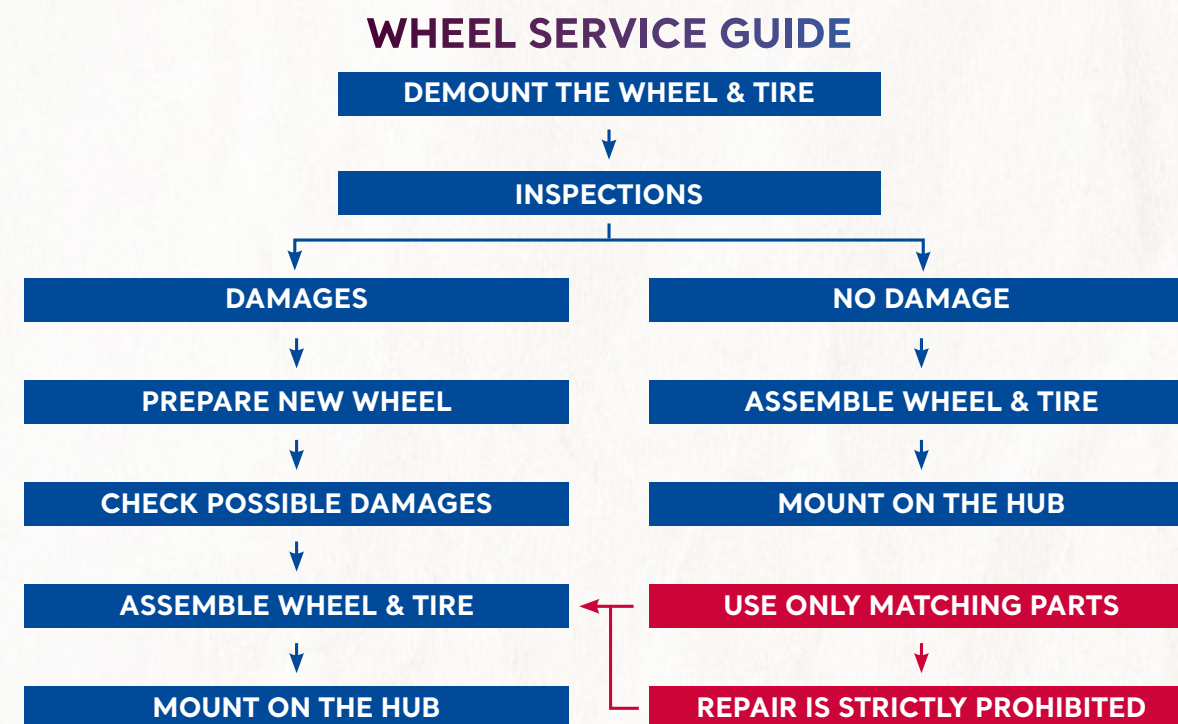

WARRANTY POLICY

1. JANTSA A.S. warranties that delivered goods are free from defects in materials and workmanship and are produced according to provided technical documentation. The warranty period for these defects is 24 months from the passage of risk.
2. The Buyer has to examine delivered goods immediately upon receiving them, and provide written notification of all discovered defects or incomplete delivery no later than within 10 days after receipt of goods. Otherwise delivery of goods and quality of delivered goods are considered as accepted.
3. Normal wear is not covered with warranty. The warranty also does not cover damage resulting from improper usage of products, for example excess of loading norms or inflating tires stipulated by ETRTO (European Tyre and Rim Technical Organization), or using tires which do not correspond to ETRTO standard.
4. JANTSA A.S. does not bear obligation under warranty for goods if they were modified, or processed (including welding of disc to rim, drilling of stud holes, mechanical processing of surface, etc.). Repair of disc wheels is strictly prohibited.
5. JANTSA A.S. does not bear obligation under warranty for goods if spare parts produced by other manufacturers are used with them.
6. The Buyer should bear full responsibility for proving all conditions required to put forward a claim, in particular, proving presence of defect itself, the time at which the defect was discovered, and the fact that notification of defect was sent on time.
7. JANTSA A.S. bears responsibility for defects and damages which appear during transportation in limits of INCOTERMS 2010 delivery terms, according to which the deliveries are performed.
8. JANTSA A.S. warranties, that proved defects will be corrected either through replacement of goods or through compensation of their EXW price at the moment of initial delivery of goods.



 **Jantosa**





 Umurlu Mah. Organize Sanayi Bölgesi Cad.
No: 58-59/1, 09630 Efeler-Aydın-Turkey

 +90 (256) 259 11 25

 +90 (256) 259 11 24

www.jantsa.com